

# EX-45034IS

RS-232/422/485 PCI-Express Karte  
mit 4x 9 Pin Anschluss  
Überspannungsschutz & Isolierung

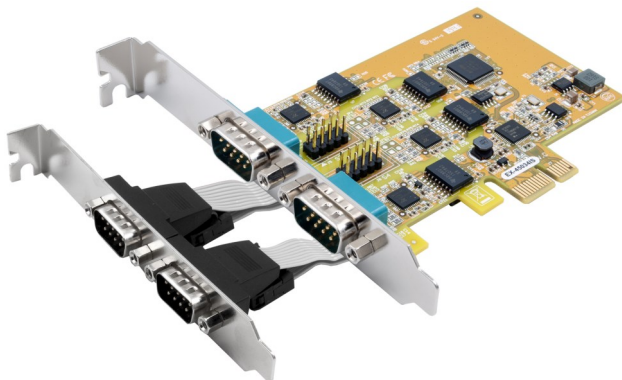

RS-232/422/485 PCI-Express Card  
with 4x 9 Pin Connector  
Surge Protection & Isolation

**Deutschland:**  
EXSYS Vertriebs GmbH  
Industriestraße 8  
61449 Steinbach  
[www.exsys.de](http://www.exsys.de)

**Schweiz:**  
EXSYS Vertriebs GmbH  
Dübendorfstrasse 17  
8602 Wangen  
[www.exsys.ch](http://www.exsys.ch)

**Italia:**  
EXSYS Italia Srl  
Via Belvedere, 45/B  
I-22100 Como  
[www.exsys.it](http://www.exsys.it)



## Inhaltsverzeichnis

|                                |      |
|--------------------------------|------|
| 1. Beschreibung .....          | 3    |
| 2. Lieferumfang .....          | 3    |
| 3. Aufbau und Anschlüsse ..... | 4-5  |
| 3.1 Aufbau .....               | 4    |
| 3.2 Anschlüsse .....           | 4-5  |
| 4. Switch Einstellungen .....  | 5-8  |
| 5. Hardware Installation ..... | 9    |
| 6. Treiber Installation .....  | 9-11 |
| 7. Technische Daten .....      | 11   |

## Index

|                                 |       |
|---------------------------------|-------|
| 1. Description .....            | 12    |
| 2. Extent of Delivery .....     | 12    |
| 3. Layout and Connections ..... | 13-14 |
| 3.1 Layout .....                | 13    |
| 3.2 Connections .....           | 13-14 |
| 4. Switch Settings .....        | 14-17 |
| 5. Hardware Installation .....  | 18    |
| 6. Driver Installation .....    | 18-20 |
| 7. Technical Information .....  | 20    |

## 1. Beschreibung

Die EX-45034IS PCIe I/O Karte stellt vier serielle RS-232, 422 und 485 High Performance UART 16C550 Ausgänge mit 15KV ESD Überspannungsschutz und 2.5KV Isolation zur Verfügung. Sie wurde entwickelt um vier weitere serielle Ports für PC, Workstation oder Server über den PCIe Bus zu erweitern. Die Karte ist voll Plug-and-Play kompatibel. Sie unterstützt die Merkmale ATTA Auto RS-485 Transmitter. Für jeden Port kann die Übertragungsart RS-232, 422 oder 485 individuell eingestellt werden.

### Merkmale:

- PCI-Express x1 bis x16
- 300 Baud bis 921.6 KBAud
- RS-232, RS-422, 2 Draht RS-485 und 4 Draht RS-485
- 15KV ESD Überspannungsschutz & 2.5KV Isolierung

## 2. Lieferumfang

Bevor Sie die EX-45034IS in Ihren PC installieren, überprüfen Sie bitte zuerst den Inhalt der Lieferung:

- EX-45034IS
- Treiber CD
- Bedienungsanleitung
- Bügel mit 2x 9 Pin Kabel

### 3. Aufbau und Anschlüsse

#### 3.1 Aufbau

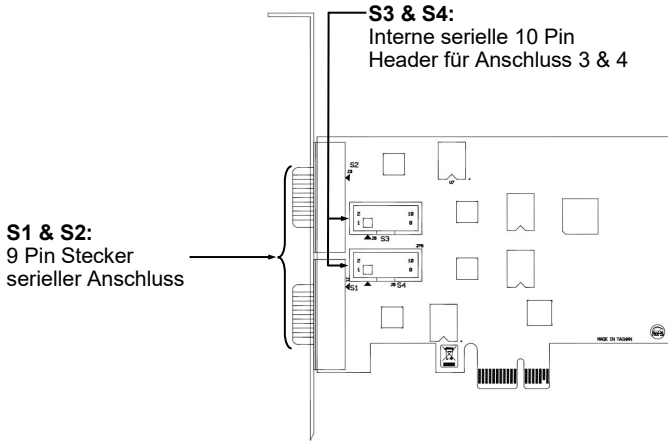

#### 3.2 Anschlüsse

RS232 Pin Assignment

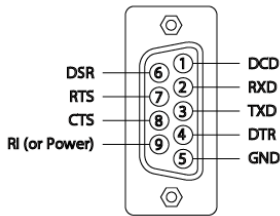

RS422 and RS485-4wire Pin Assignment

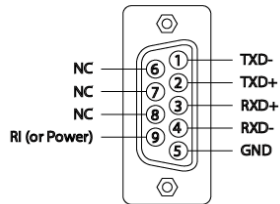

**DB9 (EX-45034IS)**

**DB9 (Endgerät)**

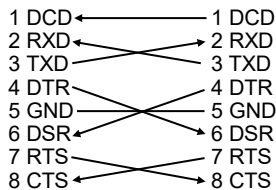

**DB9 (EX-45034IS)**

**DB9 (Endgerät)**

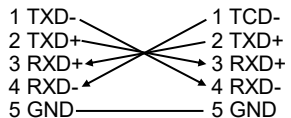

### 3. Aufbau und Anschlüsse

#### 3.2 Anschlüsse

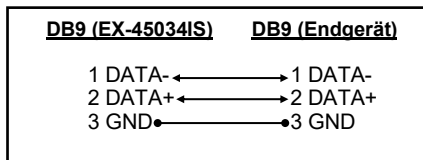
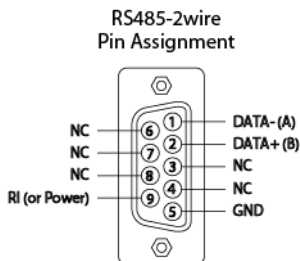

### 4. Switch Einstellungen

Es gibt vier 8-Pin DIP-Schalter auf der Rückseite der Platine der EX-45034IS. Für jeden Port gibt es einen separaten DIP-Schalter. Die 8-Pin DIP-Schalter sind für den Mode (RS-232, RS-422, RS-485 2-Draht oder RS-485 4-Draht) und die Terminierung der Signale RX+, RX-, TX+ und TX- zuständig (siehe Bild auf Seite 6). Die Einstellungen sind für jeden seriellen Port individuell einstellbar. Der DIP-Switch S1 ist für den Anschluss 1 zuständig, der zweite DIP-Switch S2 ist für den Anschluss 2 zuständig usw.. Aus den nachfolgenden Abbildungen auf Seite 6, 7 und 8 können Sie die Einstellung des Mode Switch und der Terminator Switches entnehmen. Zusätzlich sind auf der Rückseite der Platine die Einstellmöglichkeiten des Mode und Terminator Switches aufgedruckt.

## 4. Switch Einstellungen

### Mode & Terminator Switch (S1-S4\_Mode)

| Modes  | RS-232                                                                                                                                                                                                                                                                                                                                                                 | RS-422 | RS-485 2-Draht | RS-485 4-Draht |    |   |   |    |   |   |      |   |   |    |   |   |    |   |   |    |   |   |    |   |   |                                                                                                                                                                                                                                                                                                                                                                        |    |   |    |    |   |   |    |   |   |      |   |   |    |   |   |    |   |   |    |   |   |    |   |   |                                                                                                                                                                                                                                                                                                                                                                        |    |   |    |    |   |   |    |   |   |      |   |   |    |   |   |    |   |   |    |   |   |    |   |   |                                                                                                                                                                                                                                                                                                                                                                        |    |   |    |    |   |   |    |   |   |      |   |   |    |   |   |    |   |   |    |   |   |    |   |   |
|--------|------------------------------------------------------------------------------------------------------------------------------------------------------------------------------------------------------------------------------------------------------------------------------------------------------------------------------------------------------------------------|--------|----------------|----------------|----|---|---|----|---|---|------|---|---|----|---|---|----|---|---|----|---|---|----|---|---|------------------------------------------------------------------------------------------------------------------------------------------------------------------------------------------------------------------------------------------------------------------------------------------------------------------------------------------------------------------------|----|---|----|----|---|---|----|---|---|------|---|---|----|---|---|----|---|---|----|---|---|----|---|---|------------------------------------------------------------------------------------------------------------------------------------------------------------------------------------------------------------------------------------------------------------------------------------------------------------------------------------------------------------------------|----|---|----|----|---|---|----|---|---|------|---|---|----|---|---|----|---|---|----|---|---|----|---|---|------------------------------------------------------------------------------------------------------------------------------------------------------------------------------------------------------------------------------------------------------------------------------------------------------------------------------------------------------------------------|----|---|----|----|---|---|----|---|---|------|---|---|----|---|---|----|---|---|----|---|---|----|---|---|
| Port 1 | <table border="1"> <tr><td>M0</td><td>1</td><td>ON</td></tr> <tr><td>M1</td><td>2</td><td>■</td></tr> <tr><td>M2</td><td>3</td><td>■</td></tr> <tr><td>TERM</td><td>4</td><td>■</td></tr> <tr><td>T+</td><td>5</td><td>■</td></tr> <tr><td>T-</td><td>6</td><td>■</td></tr> <tr><td>R+</td><td>7</td><td>■</td></tr> <tr><td>R-</td><td>8</td><td>■</td></tr> </table> | M0     | 1              | ON             | M1 | 2 | ■ | M2 | 3 | ■ | TERM | 4 | ■ | T+ | 5 | ■ | T- | 6 | ■ | R+ | 7 | ■ | R- | 8 | ■ | <table border="1"> <tr><td>M0</td><td>1</td><td>ON</td></tr> <tr><td>M1</td><td>2</td><td>■</td></tr> <tr><td>M2</td><td>3</td><td>■</td></tr> <tr><td>TERM</td><td>4</td><td>■</td></tr> <tr><td>T+</td><td>5</td><td>■</td></tr> <tr><td>T-</td><td>6</td><td>■</td></tr> <tr><td>R+</td><td>7</td><td>■</td></tr> <tr><td>R-</td><td>8</td><td>■</td></tr> </table> | M0 | 1 | ON | M1 | 2 | ■ | M2 | 3 | ■ | TERM | 4 | ■ | T+ | 5 | ■ | T- | 6 | ■ | R+ | 7 | ■ | R- | 8 | ■ | <table border="1"> <tr><td>M0</td><td>1</td><td>ON</td></tr> <tr><td>M1</td><td>2</td><td>■</td></tr> <tr><td>M2</td><td>3</td><td>■</td></tr> <tr><td>TERM</td><td>4</td><td>■</td></tr> <tr><td>T+</td><td>5</td><td>■</td></tr> <tr><td>T-</td><td>6</td><td>■</td></tr> <tr><td>R+</td><td>7</td><td>■</td></tr> <tr><td>R-</td><td>8</td><td>■</td></tr> </table> | M0 | 1 | ON | M1 | 2 | ■ | M2 | 3 | ■ | TERM | 4 | ■ | T+ | 5 | ■ | T- | 6 | ■ | R+ | 7 | ■ | R- | 8 | ■ | <table border="1"> <tr><td>M0</td><td>1</td><td>ON</td></tr> <tr><td>M1</td><td>2</td><td>■</td></tr> <tr><td>M2</td><td>3</td><td>■</td></tr> <tr><td>TERM</td><td>4</td><td>■</td></tr> <tr><td>T+</td><td>5</td><td>■</td></tr> <tr><td>T-</td><td>6</td><td>■</td></tr> <tr><td>R+</td><td>7</td><td>■</td></tr> <tr><td>R-</td><td>8</td><td>■</td></tr> </table> | M0 | 1 | ON | M1 | 2 | ■ | M2 | 3 | ■ | TERM | 4 | ■ | T+ | 5 | ■ | T- | 6 | ■ | R+ | 7 | ■ | R- | 8 | ■ |
| M0     | 1                                                                                                                                                                                                                                                                                                                                                                      | ON     |                |                |    |   |   |    |   |   |      |   |   |    |   |   |    |   |   |    |   |   |    |   |   |                                                                                                                                                                                                                                                                                                                                                                        |    |   |    |    |   |   |    |   |   |      |   |   |    |   |   |    |   |   |    |   |   |    |   |   |                                                                                                                                                                                                                                                                                                                                                                        |    |   |    |    |   |   |    |   |   |      |   |   |    |   |   |    |   |   |    |   |   |    |   |   |                                                                                                                                                                                                                                                                                                                                                                        |    |   |    |    |   |   |    |   |   |      |   |   |    |   |   |    |   |   |    |   |   |    |   |   |
| M1     | 2                                                                                                                                                                                                                                                                                                                                                                      | ■      |                |                |    |   |   |    |   |   |      |   |   |    |   |   |    |   |   |    |   |   |    |   |   |                                                                                                                                                                                                                                                                                                                                                                        |    |   |    |    |   |   |    |   |   |      |   |   |    |   |   |    |   |   |    |   |   |    |   |   |                                                                                                                                                                                                                                                                                                                                                                        |    |   |    |    |   |   |    |   |   |      |   |   |    |   |   |    |   |   |    |   |   |    |   |   |                                                                                                                                                                                                                                                                                                                                                                        |    |   |    |    |   |   |    |   |   |      |   |   |    |   |   |    |   |   |    |   |   |    |   |   |
| M2     | 3                                                                                                                                                                                                                                                                                                                                                                      | ■      |                |                |    |   |   |    |   |   |      |   |   |    |   |   |    |   |   |    |   |   |    |   |   |                                                                                                                                                                                                                                                                                                                                                                        |    |   |    |    |   |   |    |   |   |      |   |   |    |   |   |    |   |   |    |   |   |    |   |   |                                                                                                                                                                                                                                                                                                                                                                        |    |   |    |    |   |   |    |   |   |      |   |   |    |   |   |    |   |   |    |   |   |    |   |   |                                                                                                                                                                                                                                                                                                                                                                        |    |   |    |    |   |   |    |   |   |      |   |   |    |   |   |    |   |   |    |   |   |    |   |   |
| TERM   | 4                                                                                                                                                                                                                                                                                                                                                                      | ■      |                |                |    |   |   |    |   |   |      |   |   |    |   |   |    |   |   |    |   |   |    |   |   |                                                                                                                                                                                                                                                                                                                                                                        |    |   |    |    |   |   |    |   |   |      |   |   |    |   |   |    |   |   |    |   |   |    |   |   |                                                                                                                                                                                                                                                                                                                                                                        |    |   |    |    |   |   |    |   |   |      |   |   |    |   |   |    |   |   |    |   |   |    |   |   |                                                                                                                                                                                                                                                                                                                                                                        |    |   |    |    |   |   |    |   |   |      |   |   |    |   |   |    |   |   |    |   |   |    |   |   |
| T+     | 5                                                                                                                                                                                                                                                                                                                                                                      | ■      |                |                |    |   |   |    |   |   |      |   |   |    |   |   |    |   |   |    |   |   |    |   |   |                                                                                                                                                                                                                                                                                                                                                                        |    |   |    |    |   |   |    |   |   |      |   |   |    |   |   |    |   |   |    |   |   |    |   |   |                                                                                                                                                                                                                                                                                                                                                                        |    |   |    |    |   |   |    |   |   |      |   |   |    |   |   |    |   |   |    |   |   |    |   |   |                                                                                                                                                                                                                                                                                                                                                                        |    |   |    |    |   |   |    |   |   |      |   |   |    |   |   |    |   |   |    |   |   |    |   |   |
| T-     | 6                                                                                                                                                                                                                                                                                                                                                                      | ■      |                |                |    |   |   |    |   |   |      |   |   |    |   |   |    |   |   |    |   |   |    |   |   |                                                                                                                                                                                                                                                                                                                                                                        |    |   |    |    |   |   |    |   |   |      |   |   |    |   |   |    |   |   |    |   |   |    |   |   |                                                                                                                                                                                                                                                                                                                                                                        |    |   |    |    |   |   |    |   |   |      |   |   |    |   |   |    |   |   |    |   |   |    |   |   |                                                                                                                                                                                                                                                                                                                                                                        |    |   |    |    |   |   |    |   |   |      |   |   |    |   |   |    |   |   |    |   |   |    |   |   |
| R+     | 7                                                                                                                                                                                                                                                                                                                                                                      | ■      |                |                |    |   |   |    |   |   |      |   |   |    |   |   |    |   |   |    |   |   |    |   |   |                                                                                                                                                                                                                                                                                                                                                                        |    |   |    |    |   |   |    |   |   |      |   |   |    |   |   |    |   |   |    |   |   |    |   |   |                                                                                                                                                                                                                                                                                                                                                                        |    |   |    |    |   |   |    |   |   |      |   |   |    |   |   |    |   |   |    |   |   |    |   |   |                                                                                                                                                                                                                                                                                                                                                                        |    |   |    |    |   |   |    |   |   |      |   |   |    |   |   |    |   |   |    |   |   |    |   |   |
| R-     | 8                                                                                                                                                                                                                                                                                                                                                                      | ■      |                |                |    |   |   |    |   |   |      |   |   |    |   |   |    |   |   |    |   |   |    |   |   |                                                                                                                                                                                                                                                                                                                                                                        |    |   |    |    |   |   |    |   |   |      |   |   |    |   |   |    |   |   |    |   |   |    |   |   |                                                                                                                                                                                                                                                                                                                                                                        |    |   |    |    |   |   |    |   |   |      |   |   |    |   |   |    |   |   |    |   |   |    |   |   |                                                                                                                                                                                                                                                                                                                                                                        |    |   |    |    |   |   |    |   |   |      |   |   |    |   |   |    |   |   |    |   |   |    |   |   |
| M0     | 1                                                                                                                                                                                                                                                                                                                                                                      | ON     |                |                |    |   |   |    |   |   |      |   |   |    |   |   |    |   |   |    |   |   |    |   |   |                                                                                                                                                                                                                                                                                                                                                                        |    |   |    |    |   |   |    |   |   |      |   |   |    |   |   |    |   |   |    |   |   |    |   |   |                                                                                                                                                                                                                                                                                                                                                                        |    |   |    |    |   |   |    |   |   |      |   |   |    |   |   |    |   |   |    |   |   |    |   |   |                                                                                                                                                                                                                                                                                                                                                                        |    |   |    |    |   |   |    |   |   |      |   |   |    |   |   |    |   |   |    |   |   |    |   |   |
| M1     | 2                                                                                                                                                                                                                                                                                                                                                                      | ■      |                |                |    |   |   |    |   |   |      |   |   |    |   |   |    |   |   |    |   |   |    |   |   |                                                                                                                                                                                                                                                                                                                                                                        |    |   |    |    |   |   |    |   |   |      |   |   |    |   |   |    |   |   |    |   |   |    |   |   |                                                                                                                                                                                                                                                                                                                                                                        |    |   |    |    |   |   |    |   |   |      |   |   |    |   |   |    |   |   |    |   |   |    |   |   |                                                                                                                                                                                                                                                                                                                                                                        |    |   |    |    |   |   |    |   |   |      |   |   |    |   |   |    |   |   |    |   |   |    |   |   |
| M2     | 3                                                                                                                                                                                                                                                                                                                                                                      | ■      |                |                |    |   |   |    |   |   |      |   |   |    |   |   |    |   |   |    |   |   |    |   |   |                                                                                                                                                                                                                                                                                                                                                                        |    |   |    |    |   |   |    |   |   |      |   |   |    |   |   |    |   |   |    |   |   |    |   |   |                                                                                                                                                                                                                                                                                                                                                                        |    |   |    |    |   |   |    |   |   |      |   |   |    |   |   |    |   |   |    |   |   |    |   |   |                                                                                                                                                                                                                                                                                                                                                                        |    |   |    |    |   |   |    |   |   |      |   |   |    |   |   |    |   |   |    |   |   |    |   |   |
| TERM   | 4                                                                                                                                                                                                                                                                                                                                                                      | ■      |                |                |    |   |   |    |   |   |      |   |   |    |   |   |    |   |   |    |   |   |    |   |   |                                                                                                                                                                                                                                                                                                                                                                        |    |   |    |    |   |   |    |   |   |      |   |   |    |   |   |    |   |   |    |   |   |    |   |   |                                                                                                                                                                                                                                                                                                                                                                        |    |   |    |    |   |   |    |   |   |      |   |   |    |   |   |    |   |   |    |   |   |    |   |   |                                                                                                                                                                                                                                                                                                                                                                        |    |   |    |    |   |   |    |   |   |      |   |   |    |   |   |    |   |   |    |   |   |    |   |   |
| T+     | 5                                                                                                                                                                                                                                                                                                                                                                      | ■      |                |                |    |   |   |    |   |   |      |   |   |    |   |   |    |   |   |    |   |   |    |   |   |                                                                                                                                                                                                                                                                                                                                                                        |    |   |    |    |   |   |    |   |   |      |   |   |    |   |   |    |   |   |    |   |   |    |   |   |                                                                                                                                                                                                                                                                                                                                                                        |    |   |    |    |   |   |    |   |   |      |   |   |    |   |   |    |   |   |    |   |   |    |   |   |                                                                                                                                                                                                                                                                                                                                                                        |    |   |    |    |   |   |    |   |   |      |   |   |    |   |   |    |   |   |    |   |   |    |   |   |
| T-     | 6                                                                                                                                                                                                                                                                                                                                                                      | ■      |                |                |    |   |   |    |   |   |      |   |   |    |   |   |    |   |   |    |   |   |    |   |   |                                                                                                                                                                                                                                                                                                                                                                        |    |   |    |    |   |   |    |   |   |      |   |   |    |   |   |    |   |   |    |   |   |    |   |   |                                                                                                                                                                                                                                                                                                                                                                        |    |   |    |    |   |   |    |   |   |      |   |   |    |   |   |    |   |   |    |   |   |    |   |   |                                                                                                                                                                                                                                                                                                                                                                        |    |   |    |    |   |   |    |   |   |      |   |   |    |   |   |    |   |   |    |   |   |    |   |   |
| R+     | 7                                                                                                                                                                                                                                                                                                                                                                      | ■      |                |                |    |   |   |    |   |   |      |   |   |    |   |   |    |   |   |    |   |   |    |   |   |                                                                                                                                                                                                                                                                                                                                                                        |    |   |    |    |   |   |    |   |   |      |   |   |    |   |   |    |   |   |    |   |   |    |   |   |                                                                                                                                                                                                                                                                                                                                                                        |    |   |    |    |   |   |    |   |   |      |   |   |    |   |   |    |   |   |    |   |   |    |   |   |                                                                                                                                                                                                                                                                                                                                                                        |    |   |    |    |   |   |    |   |   |      |   |   |    |   |   |    |   |   |    |   |   |    |   |   |
| R-     | 8                                                                                                                                                                                                                                                                                                                                                                      | ■      |                |                |    |   |   |    |   |   |      |   |   |    |   |   |    |   |   |    |   |   |    |   |   |                                                                                                                                                                                                                                                                                                                                                                        |    |   |    |    |   |   |    |   |   |      |   |   |    |   |   |    |   |   |    |   |   |    |   |   |                                                                                                                                                                                                                                                                                                                                                                        |    |   |    |    |   |   |    |   |   |      |   |   |    |   |   |    |   |   |    |   |   |    |   |   |                                                                                                                                                                                                                                                                                                                                                                        |    |   |    |    |   |   |    |   |   |      |   |   |    |   |   |    |   |   |    |   |   |    |   |   |
| M0     | 1                                                                                                                                                                                                                                                                                                                                                                      | ON     |                |                |    |   |   |    |   |   |      |   |   |    |   |   |    |   |   |    |   |   |    |   |   |                                                                                                                                                                                                                                                                                                                                                                        |    |   |    |    |   |   |    |   |   |      |   |   |    |   |   |    |   |   |    |   |   |    |   |   |                                                                                                                                                                                                                                                                                                                                                                        |    |   |    |    |   |   |    |   |   |      |   |   |    |   |   |    |   |   |    |   |   |    |   |   |                                                                                                                                                                                                                                                                                                                                                                        |    |   |    |    |   |   |    |   |   |      |   |   |    |   |   |    |   |   |    |   |   |    |   |   |
| M1     | 2                                                                                                                                                                                                                                                                                                                                                                      | ■      |                |                |    |   |   |    |   |   |      |   |   |    |   |   |    |   |   |    |   |   |    |   |   |                                                                                                                                                                                                                                                                                                                                                                        |    |   |    |    |   |   |    |   |   |      |   |   |    |   |   |    |   |   |    |   |   |    |   |   |                                                                                                                                                                                                                                                                                                                                                                        |    |   |    |    |   |   |    |   |   |      |   |   |    |   |   |    |   |   |    |   |   |    |   |   |                                                                                                                                                                                                                                                                                                                                                                        |    |   |    |    |   |   |    |   |   |      |   |   |    |   |   |    |   |   |    |   |   |    |   |   |
| M2     | 3                                                                                                                                                                                                                                                                                                                                                                      | ■      |                |                |    |   |   |    |   |   |      |   |   |    |   |   |    |   |   |    |   |   |    |   |   |                                                                                                                                                                                                                                                                                                                                                                        |    |   |    |    |   |   |    |   |   |      |   |   |    |   |   |    |   |   |    |   |   |    |   |   |                                                                                                                                                                                                                                                                                                                                                                        |    |   |    |    |   |   |    |   |   |      |   |   |    |   |   |    |   |   |    |   |   |    |   |   |                                                                                                                                                                                                                                                                                                                                                                        |    |   |    |    |   |   |    |   |   |      |   |   |    |   |   |    |   |   |    |   |   |    |   |   |
| TERM   | 4                                                                                                                                                                                                                                                                                                                                                                      | ■      |                |                |    |   |   |    |   |   |      |   |   |    |   |   |    |   |   |    |   |   |    |   |   |                                                                                                                                                                                                                                                                                                                                                                        |    |   |    |    |   |   |    |   |   |      |   |   |    |   |   |    |   |   |    |   |   |    |   |   |                                                                                                                                                                                                                                                                                                                                                                        |    |   |    |    |   |   |    |   |   |      |   |   |    |   |   |    |   |   |    |   |   |    |   |   |                                                                                                                                                                                                                                                                                                                                                                        |    |   |    |    |   |   |    |   |   |      |   |   |    |   |   |    |   |   |    |   |   |    |   |   |
| T+     | 5                                                                                                                                                                                                                                                                                                                                                                      | ■      |                |                |    |   |   |    |   |   |      |   |   |    |   |   |    |   |   |    |   |   |    |   |   |                                                                                                                                                                                                                                                                                                                                                                        |    |   |    |    |   |   |    |   |   |      |   |   |    |   |   |    |   |   |    |   |   |    |   |   |                                                                                                                                                                                                                                                                                                                                                                        |    |   |    |    |   |   |    |   |   |      |   |   |    |   |   |    |   |   |    |   |   |    |   |   |                                                                                                                                                                                                                                                                                                                                                                        |    |   |    |    |   |   |    |   |   |      |   |   |    |   |   |    |   |   |    |   |   |    |   |   |
| T-     | 6                                                                                                                                                                                                                                                                                                                                                                      | ■      |                |                |    |   |   |    |   |   |      |   |   |    |   |   |    |   |   |    |   |   |    |   |   |                                                                                                                                                                                                                                                                                                                                                                        |    |   |    |    |   |   |    |   |   |      |   |   |    |   |   |    |   |   |    |   |   |    |   |   |                                                                                                                                                                                                                                                                                                                                                                        |    |   |    |    |   |   |    |   |   |      |   |   |    |   |   |    |   |   |    |   |   |    |   |   |                                                                                                                                                                                                                                                                                                                                                                        |    |   |    |    |   |   |    |   |   |      |   |   |    |   |   |    |   |   |    |   |   |    |   |   |
| R+     | 7                                                                                                                                                                                                                                                                                                                                                                      | ■      |                |                |    |   |   |    |   |   |      |   |   |    |   |   |    |   |   |    |   |   |    |   |   |                                                                                                                                                                                                                                                                                                                                                                        |    |   |    |    |   |   |    |   |   |      |   |   |    |   |   |    |   |   |    |   |   |    |   |   |                                                                                                                                                                                                                                                                                                                                                                        |    |   |    |    |   |   |    |   |   |      |   |   |    |   |   |    |   |   |    |   |   |    |   |   |                                                                                                                                                                                                                                                                                                                                                                        |    |   |    |    |   |   |    |   |   |      |   |   |    |   |   |    |   |   |    |   |   |    |   |   |
| R-     | 8                                                                                                                                                                                                                                                                                                                                                                      | ■      |                |                |    |   |   |    |   |   |      |   |   |    |   |   |    |   |   |    |   |   |    |   |   |                                                                                                                                                                                                                                                                                                                                                                        |    |   |    |    |   |   |    |   |   |      |   |   |    |   |   |    |   |   |    |   |   |    |   |   |                                                                                                                                                                                                                                                                                                                                                                        |    |   |    |    |   |   |    |   |   |      |   |   |    |   |   |    |   |   |    |   |   |    |   |   |                                                                                                                                                                                                                                                                                                                                                                        |    |   |    |    |   |   |    |   |   |      |   |   |    |   |   |    |   |   |    |   |   |    |   |   |
| M0     | 1                                                                                                                                                                                                                                                                                                                                                                      | ON     |                |                |    |   |   |    |   |   |      |   |   |    |   |   |    |   |   |    |   |   |    |   |   |                                                                                                                                                                                                                                                                                                                                                                        |    |   |    |    |   |   |    |   |   |      |   |   |    |   |   |    |   |   |    |   |   |    |   |   |                                                                                                                                                                                                                                                                                                                                                                        |    |   |    |    |   |   |    |   |   |      |   |   |    |   |   |    |   |   |    |   |   |    |   |   |                                                                                                                                                                                                                                                                                                                                                                        |    |   |    |    |   |   |    |   |   |      |   |   |    |   |   |    |   |   |    |   |   |    |   |   |
| M1     | 2                                                                                                                                                                                                                                                                                                                                                                      | ■      |                |                |    |   |   |    |   |   |      |   |   |    |   |   |    |   |   |    |   |   |    |   |   |                                                                                                                                                                                                                                                                                                                                                                        |    |   |    |    |   |   |    |   |   |      |   |   |    |   |   |    |   |   |    |   |   |    |   |   |                                                                                                                                                                                                                                                                                                                                                                        |    |   |    |    |   |   |    |   |   |      |   |   |    |   |   |    |   |   |    |   |   |    |   |   |                                                                                                                                                                                                                                                                                                                                                                        |    |   |    |    |   |   |    |   |   |      |   |   |    |   |   |    |   |   |    |   |   |    |   |   |
| M2     | 3                                                                                                                                                                                                                                                                                                                                                                      | ■      |                |                |    |   |   |    |   |   |      |   |   |    |   |   |    |   |   |    |   |   |    |   |   |                                                                                                                                                                                                                                                                                                                                                                        |    |   |    |    |   |   |    |   |   |      |   |   |    |   |   |    |   |   |    |   |   |    |   |   |                                                                                                                                                                                                                                                                                                                                                                        |    |   |    |    |   |   |    |   |   |      |   |   |    |   |   |    |   |   |    |   |   |    |   |   |                                                                                                                                                                                                                                                                                                                                                                        |    |   |    |    |   |   |    |   |   |      |   |   |    |   |   |    |   |   |    |   |   |    |   |   |
| TERM   | 4                                                                                                                                                                                                                                                                                                                                                                      | ■      |                |                |    |   |   |    |   |   |      |   |   |    |   |   |    |   |   |    |   |   |    |   |   |                                                                                                                                                                                                                                                                                                                                                                        |    |   |    |    |   |   |    |   |   |      |   |   |    |   |   |    |   |   |    |   |   |    |   |   |                                                                                                                                                                                                                                                                                                                                                                        |    |   |    |    |   |   |    |   |   |      |   |   |    |   |   |    |   |   |    |   |   |    |   |   |                                                                                                                                                                                                                                                                                                                                                                        |    |   |    |    |   |   |    |   |   |      |   |   |    |   |   |    |   |   |    |   |   |    |   |   |
| T+     | 5                                                                                                                                                                                                                                                                                                                                                                      | ■      |                |                |    |   |   |    |   |   |      |   |   |    |   |   |    |   |   |    |   |   |    |   |   |                                                                                                                                                                                                                                                                                                                                                                        |    |   |    |    |   |   |    |   |   |      |   |   |    |   |   |    |   |   |    |   |   |    |   |   |                                                                                                                                                                                                                                                                                                                                                                        |    |   |    |    |   |   |    |   |   |      |   |   |    |   |   |    |   |   |    |   |   |    |   |   |                                                                                                                                                                                                                                                                                                                                                                        |    |   |    |    |   |   |    |   |   |      |   |   |    |   |   |    |   |   |    |   |   |    |   |   |
| T-     | 6                                                                                                                                                                                                                                                                                                                                                                      | ■      |                |                |    |   |   |    |   |   |      |   |   |    |   |   |    |   |   |    |   |   |    |   |   |                                                                                                                                                                                                                                                                                                                                                                        |    |   |    |    |   |   |    |   |   |      |   |   |    |   |   |    |   |   |    |   |   |    |   |   |                                                                                                                                                                                                                                                                                                                                                                        |    |   |    |    |   |   |    |   |   |      |   |   |    |   |   |    |   |   |    |   |   |    |   |   |                                                                                                                                                                                                                                                                                                                                                                        |    |   |    |    |   |   |    |   |   |      |   |   |    |   |   |    |   |   |    |   |   |    |   |   |
| R+     | 7                                                                                                                                                                                                                                                                                                                                                                      | ■      |                |                |    |   |   |    |   |   |      |   |   |    |   |   |    |   |   |    |   |   |    |   |   |                                                                                                                                                                                                                                                                                                                                                                        |    |   |    |    |   |   |    |   |   |      |   |   |    |   |   |    |   |   |    |   |   |    |   |   |                                                                                                                                                                                                                                                                                                                                                                        |    |   |    |    |   |   |    |   |   |      |   |   |    |   |   |    |   |   |    |   |   |    |   |   |                                                                                                                                                                                                                                                                                                                                                                        |    |   |    |    |   |   |    |   |   |      |   |   |    |   |   |    |   |   |    |   |   |    |   |   |
| R-     | 8                                                                                                                                                                                                                                                                                                                                                                      | ■      |                |                |    |   |   |    |   |   |      |   |   |    |   |   |    |   |   |    |   |   |    |   |   |                                                                                                                                                                                                                                                                                                                                                                        |    |   |    |    |   |   |    |   |   |      |   |   |    |   |   |    |   |   |    |   |   |    |   |   |                                                                                                                                                                                                                                                                                                                                                                        |    |   |    |    |   |   |    |   |   |      |   |   |    |   |   |    |   |   |    |   |   |    |   |   |                                                                                                                                                                                                                                                                                                                                                                        |    |   |    |    |   |   |    |   |   |      |   |   |    |   |   |    |   |   |    |   |   |    |   |   |
| Port 2 | <table border="1"> <tr><td>M0</td><td>1</td><td>ON</td></tr> <tr><td>M1</td><td>2</td><td>■</td></tr> <tr><td>M2</td><td>3</td><td>■</td></tr> <tr><td>TERM</td><td>4</td><td>■</td></tr> <tr><td>T+</td><td>5</td><td>■</td></tr> <tr><td>T-</td><td>6</td><td>■</td></tr> <tr><td>R+</td><td>7</td><td>■</td></tr> <tr><td>R-</td><td>8</td><td>■</td></tr> </table> | M0     | 1              | ON             | M1 | 2 | ■ | M2 | 3 | ■ | TERM | 4 | ■ | T+ | 5 | ■ | T- | 6 | ■ | R+ | 7 | ■ | R- | 8 | ■ | <table border="1"> <tr><td>M0</td><td>1</td><td>ON</td></tr> <tr><td>M1</td><td>2</td><td>■</td></tr> <tr><td>M2</td><td>3</td><td>■</td></tr> <tr><td>TERM</td><td>4</td><td>■</td></tr> <tr><td>T+</td><td>5</td><td>■</td></tr> <tr><td>T-</td><td>6</td><td>■</td></tr> <tr><td>R+</td><td>7</td><td>■</td></tr> <tr><td>R-</td><td>8</td><td>■</td></tr> </table> | M0 | 1 | ON | M1 | 2 | ■ | M2 | 3 | ■ | TERM | 4 | ■ | T+ | 5 | ■ | T- | 6 | ■ | R+ | 7 | ■ | R- | 8 | ■ | <table border="1"> <tr><td>M0</td><td>1</td><td>ON</td></tr> <tr><td>M1</td><td>2</td><td>■</td></tr> <tr><td>M2</td><td>3</td><td>■</td></tr> <tr><td>TERM</td><td>4</td><td>■</td></tr> <tr><td>T+</td><td>5</td><td>■</td></tr> <tr><td>T-</td><td>6</td><td>■</td></tr> <tr><td>R+</td><td>7</td><td>■</td></tr> <tr><td>R-</td><td>8</td><td>■</td></tr> </table> | M0 | 1 | ON | M1 | 2 | ■ | M2 | 3 | ■ | TERM | 4 | ■ | T+ | 5 | ■ | T- | 6 | ■ | R+ | 7 | ■ | R- | 8 | ■ | <table border="1"> <tr><td>M0</td><td>1</td><td>ON</td></tr> <tr><td>M1</td><td>2</td><td>■</td></tr> <tr><td>M2</td><td>3</td><td>■</td></tr> <tr><td>TERM</td><td>4</td><td>■</td></tr> <tr><td>T+</td><td>5</td><td>■</td></tr> <tr><td>T-</td><td>6</td><td>■</td></tr> <tr><td>R+</td><td>7</td><td>■</td></tr> <tr><td>R-</td><td>8</td><td>■</td></tr> </table> | M0 | 1 | ON | M1 | 2 | ■ | M2 | 3 | ■ | TERM | 4 | ■ | T+ | 5 | ■ | T- | 6 | ■ | R+ | 7 | ■ | R- | 8 | ■ |
| M0     | 1                                                                                                                                                                                                                                                                                                                                                                      | ON     |                |                |    |   |   |    |   |   |      |   |   |    |   |   |    |   |   |    |   |   |    |   |   |                                                                                                                                                                                                                                                                                                                                                                        |    |   |    |    |   |   |    |   |   |      |   |   |    |   |   |    |   |   |    |   |   |    |   |   |                                                                                                                                                                                                                                                                                                                                                                        |    |   |    |    |   |   |    |   |   |      |   |   |    |   |   |    |   |   |    |   |   |    |   |   |                                                                                                                                                                                                                                                                                                                                                                        |    |   |    |    |   |   |    |   |   |      |   |   |    |   |   |    |   |   |    |   |   |    |   |   |
| M1     | 2                                                                                                                                                                                                                                                                                                                                                                      | ■      |                |                |    |   |   |    |   |   |      |   |   |    |   |   |    |   |   |    |   |   |    |   |   |                                                                                                                                                                                                                                                                                                                                                                        |    |   |    |    |   |   |    |   |   |      |   |   |    |   |   |    |   |   |    |   |   |    |   |   |                                                                                                                                                                                                                                                                                                                                                                        |    |   |    |    |   |   |    |   |   |      |   |   |    |   |   |    |   |   |    |   |   |    |   |   |                                                                                                                                                                                                                                                                                                                                                                        |    |   |    |    |   |   |    |   |   |      |   |   |    |   |   |    |   |   |    |   |   |    |   |   |
| M2     | 3                                                                                                                                                                                                                                                                                                                                                                      | ■      |                |                |    |   |   |    |   |   |      |   |   |    |   |   |    |   |   |    |   |   |    |   |   |                                                                                                                                                                                                                                                                                                                                                                        |    |   |    |    |   |   |    |   |   |      |   |   |    |   |   |    |   |   |    |   |   |    |   |   |                                                                                                                                                                                                                                                                                                                                                                        |    |   |    |    |   |   |    |   |   |      |   |   |    |   |   |    |   |   |    |   |   |    |   |   |                                                                                                                                                                                                                                                                                                                                                                        |    |   |    |    |   |   |    |   |   |      |   |   |    |   |   |    |   |   |    |   |   |    |   |   |
| TERM   | 4                                                                                                                                                                                                                                                                                                                                                                      | ■      |                |                |    |   |   |    |   |   |      |   |   |    |   |   |    |   |   |    |   |   |    |   |   |                                                                                                                                                                                                                                                                                                                                                                        |    |   |    |    |   |   |    |   |   |      |   |   |    |   |   |    |   |   |    |   |   |    |   |   |                                                                                                                                                                                                                                                                                                                                                                        |    |   |    |    |   |   |    |   |   |      |   |   |    |   |   |    |   |   |    |   |   |    |   |   |                                                                                                                                                                                                                                                                                                                                                                        |    |   |    |    |   |   |    |   |   |      |   |   |    |   |   |    |   |   |    |   |   |    |   |   |
| T+     | 5                                                                                                                                                                                                                                                                                                                                                                      | ■      |                |                |    |   |   |    |   |   |      |   |   |    |   |   |    |   |   |    |   |   |    |   |   |                                                                                                                                                                                                                                                                                                                                                                        |    |   |    |    |   |   |    |   |   |      |   |   |    |   |   |    |   |   |    |   |   |    |   |   |                                                                                                                                                                                                                                                                                                                                                                        |    |   |    |    |   |   |    |   |   |      |   |   |    |   |   |    |   |   |    |   |   |    |   |   |                                                                                                                                                                                                                                                                                                                                                                        |    |   |    |    |   |   |    |   |   |      |   |   |    |   |   |    |   |   |    |   |   |    |   |   |
| T-     | 6                                                                                                                                                                                                                                                                                                                                                                      | ■      |                |                |    |   |   |    |   |   |      |   |   |    |   |   |    |   |   |    |   |   |    |   |   |                                                                                                                                                                                                                                                                                                                                                                        |    |   |    |    |   |   |    |   |   |      |   |   |    |   |   |    |   |   |    |   |   |    |   |   |                                                                                                                                                                                                                                                                                                                                                                        |    |   |    |    |   |   |    |   |   |      |   |   |    |   |   |    |   |   |    |   |   |    |   |   |                                                                                                                                                                                                                                                                                                                                                                        |    |   |    |    |   |   |    |   |   |      |   |   |    |   |   |    |   |   |    |   |   |    |   |   |
| R+     | 7                                                                                                                                                                                                                                                                                                                                                                      | ■      |                |                |    |   |   |    |   |   |      |   |   |    |   |   |    |   |   |    |   |   |    |   |   |                                                                                                                                                                                                                                                                                                                                                                        |    |   |    |    |   |   |    |   |   |      |   |   |    |   |   |    |   |   |    |   |   |    |   |   |                                                                                                                                                                                                                                                                                                                                                                        |    |   |    |    |   |   |    |   |   |      |   |   |    |   |   |    |   |   |    |   |   |    |   |   |                                                                                                                                                                                                                                                                                                                                                                        |    |   |    |    |   |   |    |   |   |      |   |   |    |   |   |    |   |   |    |   |   |    |   |   |
| R-     | 8                                                                                                                                                                                                                                                                                                                                                                      | ■      |                |                |    |   |   |    |   |   |      |   |   |    |   |   |    |   |   |    |   |   |    |   |   |                                                                                                                                                                                                                                                                                                                                                                        |    |   |    |    |   |   |    |   |   |      |   |   |    |   |   |    |   |   |    |   |   |    |   |   |                                                                                                                                                                                                                                                                                                                                                                        |    |   |    |    |   |   |    |   |   |      |   |   |    |   |   |    |   |   |    |   |   |    |   |   |                                                                                                                                                                                                                                                                                                                                                                        |    |   |    |    |   |   |    |   |   |      |   |   |    |   |   |    |   |   |    |   |   |    |   |   |
| M0     | 1                                                                                                                                                                                                                                                                                                                                                                      | ON     |                |                |    |   |   |    |   |   |      |   |   |    |   |   |    |   |   |    |   |   |    |   |   |                                                                                                                                                                                                                                                                                                                                                                        |    |   |    |    |   |   |    |   |   |      |   |   |    |   |   |    |   |   |    |   |   |    |   |   |                                                                                                                                                                                                                                                                                                                                                                        |    |   |    |    |   |   |    |   |   |      |   |   |    |   |   |    |   |   |    |   |   |    |   |   |                                                                                                                                                                                                                                                                                                                                                                        |    |   |    |    |   |   |    |   |   |      |   |   |    |   |   |    |   |   |    |   |   |    |   |   |
| M1     | 2                                                                                                                                                                                                                                                                                                                                                                      | ■      |                |                |    |   |   |    |   |   |      |   |   |    |   |   |    |   |   |    |   |   |    |   |   |                                                                                                                                                                                                                                                                                                                                                                        |    |   |    |    |   |   |    |   |   |      |   |   |    |   |   |    |   |   |    |   |   |    |   |   |                                                                                                                                                                                                                                                                                                                                                                        |    |   |    |    |   |   |    |   |   |      |   |   |    |   |   |    |   |   |    |   |   |    |   |   |                                                                                                                                                                                                                                                                                                                                                                        |    |   |    |    |   |   |    |   |   |      |   |   |    |   |   |    |   |   |    |   |   |    |   |   |
| M2     | 3                                                                                                                                                                                                                                                                                                                                                                      | ■      |                |                |    |   |   |    |   |   |      |   |   |    |   |   |    |   |   |    |   |   |    |   |   |                                                                                                                                                                                                                                                                                                                                                                        |    |   |    |    |   |   |    |   |   |      |   |   |    |   |   |    |   |   |    |   |   |    |   |   |                                                                                                                                                                                                                                                                                                                                                                        |    |   |    |    |   |   |    |   |   |      |   |   |    |   |   |    |   |   |    |   |   |    |   |   |                                                                                                                                                                                                                                                                                                                                                                        |    |   |    |    |   |   |    |   |   |      |   |   |    |   |   |    |   |   |    |   |   |    |   |   |
| TERM   | 4                                                                                                                                                                                                                                                                                                                                                                      | ■      |                |                |    |   |   |    |   |   |      |   |   |    |   |   |    |   |   |    |   |   |    |   |   |                                                                                                                                                                                                                                                                                                                                                                        |    |   |    |    |   |   |    |   |   |      |   |   |    |   |   |    |   |   |    |   |   |    |   |   |                                                                                                                                                                                                                                                                                                                                                                        |    |   |    |    |   |   |    |   |   |      |   |   |    |   |   |    |   |   |    |   |   |    |   |   |                                                                                                                                                                                                                                                                                                                                                                        |    |   |    |    |   |   |    |   |   |      |   |   |    |   |   |    |   |   |    |   |   |    |   |   |
| T+     | 5                                                                                                                                                                                                                                                                                                                                                                      | ■      |                |                |    |   |   |    |   |   |      |   |   |    |   |   |    |   |   |    |   |   |    |   |   |                                                                                                                                                                                                                                                                                                                                                                        |    |   |    |    |   |   |    |   |   |      |   |   |    |   |   |    |   |   |    |   |   |    |   |   |                                                                                                                                                                                                                                                                                                                                                                        |    |   |    |    |   |   |    |   |   |      |   |   |    |   |   |    |   |   |    |   |   |    |   |   |                                                                                                                                                                                                                                                                                                                                                                        |    |   |    |    |   |   |    |   |   |      |   |   |    |   |   |    |   |   |    |   |   |    |   |   |
| T-     | 6                                                                                                                                                                                                                                                                                                                                                                      | ■      |                |                |    |   |   |    |   |   |      |   |   |    |   |   |    |   |   |    |   |   |    |   |   |                                                                                                                                                                                                                                                                                                                                                                        |    |   |    |    |   |   |    |   |   |      |   |   |    |   |   |    |   |   |    |   |   |    |   |   |                                                                                                                                                                                                                                                                                                                                                                        |    |   |    |    |   |   |    |   |   |      |   |   |    |   |   |    |   |   |    |   |   |    |   |   |                                                                                                                                                                                                                                                                                                                                                                        |    |   |    |    |   |   |    |   |   |      |   |   |    |   |   |    |   |   |    |   |   |    |   |   |
| R+     | 7                                                                                                                                                                                                                                                                                                                                                                      | ■      |                |                |    |   |   |    |   |   |      |   |   |    |   |   |    |   |   |    |   |   |    |   |   |                                                                                                                                                                                                                                                                                                                                                                        |    |   |    |    |   |   |    |   |   |      |   |   |    |   |   |    |   |   |    |   |   |    |   |   |                                                                                                                                                                                                                                                                                                                                                                        |    |   |    |    |   |   |    |   |   |      |   |   |    |   |   |    |   |   |    |   |   |    |   |   |                                                                                                                                                                                                                                                                                                                                                                        |    |   |    |    |   |   |    |   |   |      |   |   |    |   |   |    |   |   |    |   |   |    |   |   |
| R-     | 8                                                                                                                                                                                                                                                                                                                                                                      | ■      |                |                |    |   |   |    |   |   |      |   |   |    |   |   |    |   |   |    |   |   |    |   |   |                                                                                                                                                                                                                                                                                                                                                                        |    |   |    |    |   |   |    |   |   |      |   |   |    |   |   |    |   |   |    |   |   |    |   |   |                                                                                                                                                                                                                                                                                                                                                                        |    |   |    |    |   |   |    |   |   |      |   |   |    |   |   |    |   |   |    |   |   |    |   |   |                                                                                                                                                                                                                                                                                                                                                                        |    |   |    |    |   |   |    |   |   |      |   |   |    |   |   |    |   |   |    |   |   |    |   |   |
| M0     | 1                                                                                                                                                                                                                                                                                                                                                                      | ON     |                |                |    |   |   |    |   |   |      |   |   |    |   |   |    |   |   |    |   |   |    |   |   |                                                                                                                                                                                                                                                                                                                                                                        |    |   |    |    |   |   |    |   |   |      |   |   |    |   |   |    |   |   |    |   |   |    |   |   |                                                                                                                                                                                                                                                                                                                                                                        |    |   |    |    |   |   |    |   |   |      |   |   |    |   |   |    |   |   |    |   |   |    |   |   |                                                                                                                                                                                                                                                                                                                                                                        |    |   |    |    |   |   |    |   |   |      |   |   |    |   |   |    |   |   |    |   |   |    |   |   |
| M1     | 2                                                                                                                                                                                                                                                                                                                                                                      | ■      |                |                |    |   |   |    |   |   |      |   |   |    |   |   |    |   |   |    |   |   |    |   |   |                                                                                                                                                                                                                                                                                                                                                                        |    |   |    |    |   |   |    |   |   |      |   |   |    |   |   |    |   |   |    |   |   |    |   |   |                                                                                                                                                                                                                                                                                                                                                                        |    |   |    |    |   |   |    |   |   |      |   |   |    |   |   |    |   |   |    |   |   |    |   |   |                                                                                                                                                                                                                                                                                                                                                                        |    |   |    |    |   |   |    |   |   |      |   |   |    |   |   |    |   |   |    |   |   |    |   |   |
| M2     | 3                                                                                                                                                                                                                                                                                                                                                                      | ■      |                |                |    |   |   |    |   |   |      |   |   |    |   |   |    |   |   |    |   |   |    |   |   |                                                                                                                                                                                                                                                                                                                                                                        |    |   |    |    |   |   |    |   |   |      |   |   |    |   |   |    |   |   |    |   |   |    |   |   |                                                                                                                                                                                                                                                                                                                                                                        |    |   |    |    |   |   |    |   |   |      |   |   |    |   |   |    |   |   |    |   |   |    |   |   |                                                                                                                                                                                                                                                                                                                                                                        |    |   |    |    |   |   |    |   |   |      |   |   |    |   |   |    |   |   |    |   |   |    |   |   |
| TERM   | 4                                                                                                                                                                                                                                                                                                                                                                      | ■      |                |                |    |   |   |    |   |   |      |   |   |    |   |   |    |   |   |    |   |   |    |   |   |                                                                                                                                                                                                                                                                                                                                                                        |    |   |    |    |   |   |    |   |   |      |   |   |    |   |   |    |   |   |    |   |   |    |   |   |                                                                                                                                                                                                                                                                                                                                                                        |    |   |    |    |   |   |    |   |   |      |   |   |    |   |   |    |   |   |    |   |   |    |   |   |                                                                                                                                                                                                                                                                                                                                                                        |    |   |    |    |   |   |    |   |   |      |   |   |    |   |   |    |   |   |    |   |   |    |   |   |
| T+     | 5                                                                                                                                                                                                                                                                                                                                                                      | ■      |                |                |    |   |   |    |   |   |      |   |   |    |   |   |    |   |   |    |   |   |    |   |   |                                                                                                                                                                                                                                                                                                                                                                        |    |   |    |    |   |   |    |   |   |      |   |   |    |   |   |    |   |   |    |   |   |    |   |   |                                                                                                                                                                                                                                                                                                                                                                        |    |   |    |    |   |   |    |   |   |      |   |   |    |   |   |    |   |   |    |   |   |    |   |   |                                                                                                                                                                                                                                                                                                                                                                        |    |   |    |    |   |   |    |   |   |      |   |   |    |   |   |    |   |   |    |   |   |    |   |   |
| T-     | 6                                                                                                                                                                                                                                                                                                                                                                      | ■      |                |                |    |   |   |    |   |   |      |   |   |    |   |   |    |   |   |    |   |   |    |   |   |                                                                                                                                                                                                                                                                                                                                                                        |    |   |    |    |   |   |    |   |   |      |   |   |    |   |   |    |   |   |    |   |   |    |   |   |                                                                                                                                                                                                                                                                                                                                                                        |    |   |    |    |   |   |    |   |   |      |   |   |    |   |   |    |   |   |    |   |   |    |   |   |                                                                                                                                                                                                                                                                                                                                                                        |    |   |    |    |   |   |    |   |   |      |   |   |    |   |   |    |   |   |    |   |   |    |   |   |
| R+     | 7                                                                                                                                                                                                                                                                                                                                                                      | ■      |                |                |    |   |   |    |   |   |      |   |   |    |   |   |    |   |   |    |   |   |    |   |   |                                                                                                                                                                                                                                                                                                                                                                        |    |   |    |    |   |   |    |   |   |      |   |   |    |   |   |    |   |   |    |   |   |    |   |   |                                                                                                                                                                                                                                                                                                                                                                        |    |   |    |    |   |   |    |   |   |      |   |   |    |   |   |    |   |   |    |   |   |    |   |   |                                                                                                                                                                                                                                                                                                                                                                        |    |   |    |    |   |   |    |   |   |      |   |   |    |   |   |    |   |   |    |   |   |    |   |   |
| R-     | 8                                                                                                                                                                                                                                                                                                                                                                      | ■      |                |                |    |   |   |    |   |   |      |   |   |    |   |   |    |   |   |    |   |   |    |   |   |                                                                                                                                                                                                                                                                                                                                                                        |    |   |    |    |   |   |    |   |   |      |   |   |    |   |   |    |   |   |    |   |   |    |   |   |                                                                                                                                                                                                                                                                                                                                                                        |    |   |    |    |   |   |    |   |   |      |   |   |    |   |   |    |   |   |    |   |   |    |   |   |                                                                                                                                                                                                                                                                                                                                                                        |    |   |    |    |   |   |    |   |   |      |   |   |    |   |   |    |   |   |    |   |   |    |   |   |
| M0     | 1                                                                                                                                                                                                                                                                                                                                                                      | ON     |                |                |    |   |   |    |   |   |      |   |   |    |   |   |    |   |   |    |   |   |    |   |   |                                                                                                                                                                                                                                                                                                                                                                        |    |   |    |    |   |   |    |   |   |      |   |   |    |   |   |    |   |   |    |   |   |    |   |   |                                                                                                                                                                                                                                                                                                                                                                        |    |   |    |    |   |   |    |   |   |      |   |   |    |   |   |    |   |   |    |   |   |    |   |   |                                                                                                                                                                                                                                                                                                                                                                        |    |   |    |    |   |   |    |   |   |      |   |   |    |   |   |    |   |   |    |   |   |    |   |   |
| M1     | 2                                                                                                                                                                                                                                                                                                                                                                      | ■      |                |                |    |   |   |    |   |   |      |   |   |    |   |   |    |   |   |    |   |   |    |   |   |                                                                                                                                                                                                                                                                                                                                                                        |    |   |    |    |   |   |    |   |   |      |   |   |    |   |   |    |   |   |    |   |   |    |   |   |                                                                                                                                                                                                                                                                                                                                                                        |    |   |    |    |   |   |    |   |   |      |   |   |    |   |   |    |   |   |    |   |   |    |   |   |                                                                                                                                                                                                                                                                                                                                                                        |    |   |    |    |   |   |    |   |   |      |   |   |    |   |   |    |   |   |    |   |   |    |   |   |
| M2     | 3                                                                                                                                                                                                                                                                                                                                                                      | ■      |                |                |    |   |   |    |   |   |      |   |   |    |   |   |    |   |   |    |   |   |    |   |   |                                                                                                                                                                                                                                                                                                                                                                        |    |   |    |    |   |   |    |   |   |      |   |   |    |   |   |    |   |   |    |   |   |    |   |   |                                                                                                                                                                                                                                                                                                                                                                        |    |   |    |    |   |   |    |   |   |      |   |   |    |   |   |    |   |   |    |   |   |    |   |   |                                                                                                                                                                                                                                                                                                                                                                        |    |   |    |    |   |   |    |   |   |      |   |   |    |   |   |    |   |   |    |   |   |    |   |   |
| TERM   | 4                                                                                                                                                                                                                                                                                                                                                                      | ■      |                |                |    |   |   |    |   |   |      |   |   |    |   |   |    |   |   |    |   |   |    |   |   |                                                                                                                                                                                                                                                                                                                                                                        |    |   |    |    |   |   |    |   |   |      |   |   |    |   |   |    |   |   |    |   |   |    |   |   |                                                                                                                                                                                                                                                                                                                                                                        |    |   |    |    |   |   |    |   |   |      |   |   |    |   |   |    |   |   |    |   |   |    |   |   |                                                                                                                                                                                                                                                                                                                                                                        |    |   |    |    |   |   |    |   |   |      |   |   |    |   |   |    |   |   |    |   |   |    |   |   |
| T+     | 5                                                                                                                                                                                                                                                                                                                                                                      | ■      |                |                |    |   |   |    |   |   |      |   |   |    |   |   |    |   |   |    |   |   |    |   |   |                                                                                                                                                                                                                                                                                                                                                                        |    |   |    |    |   |   |    |   |   |      |   |   |    |   |   |    |   |   |    |   |   |    |   |   |                                                                                                                                                                                                                                                                                                                                                                        |    |   |    |    |   |   |    |   |   |      |   |   |    |   |   |    |   |   |    |   |   |    |   |   |                                                                                                                                                                                                                                                                                                                                                                        |    |   |    |    |   |   |    |   |   |      |   |   |    |   |   |    |   |   |    |   |   |    |   |   |
| T-     | 6                                                                                                                                                                                                                                                                                                                                                                      | ■      |                |                |    |   |   |    |   |   |      |   |   |    |   |   |    |   |   |    |   |   |    |   |   |                                                                                                                                                                                                                                                                                                                                                                        |    |   |    |    |   |   |    |   |   |      |   |   |    |   |   |    |   |   |    |   |   |    |   |   |                                                                                                                                                                                                                                                                                                                                                                        |    |   |    |    |   |   |    |   |   |      |   |   |    |   |   |    |   |   |    |   |   |    |   |   |                                                                                                                                                                                                                                                                                                                                                                        |    |   |    |    |   |   |    |   |   |      |   |   |    |   |   |    |   |   |    |   |   |    |   |   |
| R+     | 7                                                                                                                                                                                                                                                                                                                                                                      | ■      |                |                |    |   |   |    |   |   |      |   |   |    |   |   |    |   |   |    |   |   |    |   |   |                                                                                                                                                                                                                                                                                                                                                                        |    |   |    |    |   |   |    |   |   |      |   |   |    |   |   |    |   |   |    |   |   |    |   |   |                                                                                                                                                                                                                                                                                                                                                                        |    |   |    |    |   |   |    |   |   |      |   |   |    |   |   |    |   |   |    |   |   |    |   |   |                                                                                                                                                                                                                                                                                                                                                                        |    |   |    |    |   |   |    |   |   |      |   |   |    |   |   |    |   |   |    |   |   |    |   |   |
| R-     | 8                                                                                                                                                                                                                                                                                                                                                                      | ■      |                |                |    |   |   |    |   |   |      |   |   |    |   |   |    |   |   |    |   |   |    |   |   |                                                                                                                                                                                                                                                                                                                                                                        |    |   |    |    |   |   |    |   |   |      |   |   |    |   |   |    |   |   |    |   |   |    |   |   |                                                                                                                                                                                                                                                                                                                                                                        |    |   |    |    |   |   |    |   |   |      |   |   |    |   |   |    |   |   |    |   |   |    |   |   |                                                                                                                                                                                                                                                                                                                                                                        |    |   |    |    |   |   |    |   |   |      |   |   |    |   |   |    |   |   |    |   |   |    |   |   |
| Port 3 | <table border="1"> <tr><td>M0</td><td>1</td><td>ON</td></tr> <tr><td>M1</td><td>2</td><td>■</td></tr> <tr><td>M2</td><td>3</td><td>■</td></tr> <tr><td>TERM</td><td>4</td><td>■</td></tr> <tr><td>T+</td><td>5</td><td>■</td></tr> <tr><td>T-</td><td>6</td><td>■</td></tr> <tr><td>R+</td><td>7</td><td>■</td></tr> <tr><td>R-</td><td>8</td><td>■</td></tr> </table> | M0     | 1              | ON             | M1 | 2 | ■ | M2 | 3 | ■ | TERM | 4 | ■ | T+ | 5 | ■ | T- | 6 | ■ | R+ | 7 | ■ | R- | 8 | ■ | <table border="1"> <tr><td>M0</td><td>1</td><td>ON</td></tr> <tr><td>M1</td><td>2</td><td>■</td></tr> <tr><td>M2</td><td>3</td><td>■</td></tr> <tr><td>TERM</td><td>4</td><td>■</td></tr> <tr><td>T+</td><td>5</td><td>■</td></tr> <tr><td>T-</td><td>6</td><td>■</td></tr> <tr><td>R+</td><td>7</td><td>■</td></tr> <tr><td>R-</td><td>8</td><td>■</td></tr> </table> | M0 | 1 | ON | M1 | 2 | ■ | M2 | 3 | ■ | TERM | 4 | ■ | T+ | 5 | ■ | T- | 6 | ■ | R+ | 7 | ■ | R- | 8 | ■ | <table border="1"> <tr><td>M0</td><td>1</td><td>ON</td></tr> <tr><td>M1</td><td>2</td><td>■</td></tr> <tr><td>M2</td><td>3</td><td>■</td></tr> <tr><td>TERM</td><td>4</td><td>■</td></tr> <tr><td>T+</td><td>5</td><td>■</td></tr> <tr><td>T-</td><td>6</td><td>■</td></tr> <tr><td>R+</td><td>7</td><td>■</td></tr> <tr><td>R-</td><td>8</td><td>■</td></tr> </table> | M0 | 1 | ON | M1 | 2 | ■ | M2 | 3 | ■ | TERM | 4 | ■ | T+ | 5 | ■ | T- | 6 | ■ | R+ | 7 | ■ | R- | 8 | ■ | <table border="1"> <tr><td>M0</td><td>1</td><td>ON</td></tr> <tr><td>M1</td><td>2</td><td>■</td></tr> <tr><td>M2</td><td>3</td><td>■</td></tr> <tr><td>TERM</td><td>4</td><td>■</td></tr> <tr><td>T+</td><td>5</td><td>■</td></tr> <tr><td>T-</td><td>6</td><td>■</td></tr> <tr><td>R+</td><td>7</td><td>■</td></tr> <tr><td>R-</td><td>8</td><td>■</td></tr> </table> | M0 | 1 | ON | M1 | 2 | ■ | M2 | 3 | ■ | TERM | 4 | ■ | T+ | 5 | ■ | T- | 6 | ■ | R+ | 7 | ■ | R- | 8 | ■ |
| M0     | 1                                                                                                                                                                                                                                                                                                                                                                      | ON     |                |                |    |   |   |    |   |   |      |   |   |    |   |   |    |   |   |    |   |   |    |   |   |                                                                                                                                                                                                                                                                                                                                                                        |    |   |    |    |   |   |    |   |   |      |   |   |    |   |   |    |   |   |    |   |   |    |   |   |                                                                                                                                                                                                                                                                                                                                                                        |    |   |    |    |   |   |    |   |   |      |   |   |    |   |   |    |   |   |    |   |   |    |   |   |                                                                                                                                                                                                                                                                                                                                                                        |    |   |    |    |   |   |    |   |   |      |   |   |    |   |   |    |   |   |    |   |   |    |   |   |
| M1     | 2                                                                                                                                                                                                                                                                                                                                                                      | ■      |                |                |    |   |   |    |   |   |      |   |   |    |   |   |    |   |   |    |   |   |    |   |   |                                                                                                                                                                                                                                                                                                                                                                        |    |   |    |    |   |   |    |   |   |      |   |   |    |   |   |    |   |   |    |   |   |    |   |   |                                                                                                                                                                                                                                                                                                                                                                        |    |   |    |    |   |   |    |   |   |      |   |   |    |   |   |    |   |   |    |   |   |    |   |   |                                                                                                                                                                                                                                                                                                                                                                        |    |   |    |    |   |   |    |   |   |      |   |   |    |   |   |    |   |   |    |   |   |    |   |   |
| M2     | 3                                                                                                                                                                                                                                                                                                                                                                      | ■      |                |                |    |   |   |    |   |   |      |   |   |    |   |   |    |   |   |    |   |   |    |   |   |                                                                                                                                                                                                                                                                                                                                                                        |    |   |    |    |   |   |    |   |   |      |   |   |    |   |   |    |   |   |    |   |   |    |   |   |                                                                                                                                                                                                                                                                                                                                                                        |    |   |    |    |   |   |    |   |   |      |   |   |    |   |   |    |   |   |    |   |   |    |   |   |                                                                                                                                                                                                                                                                                                                                                                        |    |   |    |    |   |   |    |   |   |      |   |   |    |   |   |    |   |   |    |   |   |    |   |   |
| TERM   | 4                                                                                                                                                                                                                                                                                                                                                                      | ■      |                |                |    |   |   |    |   |   |      |   |   |    |   |   |    |   |   |    |   |   |    |   |   |                                                                                                                                                                                                                                                                                                                                                                        |    |   |    |    |   |   |    |   |   |      |   |   |    |   |   |    |   |   |    |   |   |    |   |   |                                                                                                                                                                                                                                                                                                                                                                        |    |   |    |    |   |   |    |   |   |      |   |   |    |   |   |    |   |   |    |   |   |    |   |   |                                                                                                                                                                                                                                                                                                                                                                        |    |   |    |    |   |   |    |   |   |      |   |   |    |   |   |    |   |   |    |   |   |    |   |   |
| T+     | 5                                                                                                                                                                                                                                                                                                                                                                      | ■      |                |                |    |   |   |    |   |   |      |   |   |    |   |   |    |   |   |    |   |   |    |   |   |                                                                                                                                                                                                                                                                                                                                                                        |    |   |    |    |   |   |    |   |   |      |   |   |    |   |   |    |   |   |    |   |   |    |   |   |                                                                                                                                                                                                                                                                                                                                                                        |    |   |    |    |   |   |    |   |   |      |   |   |    |   |   |    |   |   |    |   |   |    |   |   |                                                                                                                                                                                                                                                                                                                                                                        |    |   |    |    |   |   |    |   |   |      |   |   |    |   |   |    |   |   |    |   |   |    |   |   |
| T-     | 6                                                                                                                                                                                                                                                                                                                                                                      | ■      |                |                |    |   |   |    |   |   |      |   |   |    |   |   |    |   |   |    |   |   |    |   |   |                                                                                                                                                                                                                                                                                                                                                                        |    |   |    |    |   |   |    |   |   |      |   |   |    |   |   |    |   |   |    |   |   |    |   |   |                                                                                                                                                                                                                                                                                                                                                                        |    |   |    |    |   |   |    |   |   |      |   |   |    |   |   |    |   |   |    |   |   |    |   |   |                                                                                                                                                                                                                                                                                                                                                                        |    |   |    |    |   |   |    |   |   |      |   |   |    |   |   |    |   |   |    |   |   |    |   |   |
| R+     | 7                                                                                                                                                                                                                                                                                                                                                                      | ■      |                |                |    |   |   |    |   |   |      |   |   |    |   |   |    |   |   |    |   |   |    |   |   |                                                                                                                                                                                                                                                                                                                                                                        |    |   |    |    |   |   |    |   |   |      |   |   |    |   |   |    |   |   |    |   |   |    |   |   |                                                                                                                                                                                                                                                                                                                                                                        |    |   |    |    |   |   |    |   |   |      |   |   |    |   |   |    |   |   |    |   |   |    |   |   |                                                                                                                                                                                                                                                                                                                                                                        |    |   |    |    |   |   |    |   |   |      |   |   |    |   |   |    |   |   |    |   |   |    |   |   |
| R-     | 8                                                                                                                                                                                                                                                                                                                                                                      | ■      |                |                |    |   |   |    |   |   |      |   |   |    |   |   |    |   |   |    |   |   |    |   |   |                                                                                                                                                                                                                                                                                                                                                                        |    |   |    |    |   |   |    |   |   |      |   |   |    |   |   |    |   |   |    |   |   |    |   |   |                                                                                                                                                                                                                                                                                                                                                                        |    |   |    |    |   |   |    |   |   |      |   |   |    |   |   |    |   |   |    |   |   |    |   |   |                                                                                                                                                                                                                                                                                                                                                                        |    |   |    |    |   |   |    |   |   |      |   |   |    |   |   |    |   |   |    |   |   |    |   |   |
| M0     | 1                                                                                                                                                                                                                                                                                                                                                                      | ON     |                |                |    |   |   |    |   |   |      |   |   |    |   |   |    |   |   |    |   |   |    |   |   |                                                                                                                                                                                                                                                                                                                                                                        |    |   |    |    |   |   |    |   |   |      |   |   |    |   |   |    |   |   |    |   |   |    |   |   |                                                                                                                                                                                                                                                                                                                                                                        |    |   |    |    |   |   |    |   |   |      |   |   |    |   |   |    |   |   |    |   |   |    |   |   |                                                                                                                                                                                                                                                                                                                                                                        |    |   |    |    |   |   |    |   |   |      |   |   |    |   |   |    |   |   |    |   |   |    |   |   |
| M1     | 2                                                                                                                                                                                                                                                                                                                                                                      | ■      |                |                |    |   |   |    |   |   |      |   |   |    |   |   |    |   |   |    |   |   |    |   |   |                                                                                                                                                                                                                                                                                                                                                                        |    |   |    |    |   |   |    |   |   |      |   |   |    |   |   |    |   |   |    |   |   |    |   |   |                                                                                                                                                                                                                                                                                                                                                                        |    |   |    |    |   |   |    |   |   |      |   |   |    |   |   |    |   |   |    |   |   |    |   |   |                                                                                                                                                                                                                                                                                                                                                                        |    |   |    |    |   |   |    |   |   |      |   |   |    |   |   |    |   |   |    |   |   |    |   |   |
| M2     | 3                                                                                                                                                                                                                                                                                                                                                                      | ■      |                |                |    |   |   |    |   |   |      |   |   |    |   |   |    |   |   |    |   |   |    |   |   |                                                                                                                                                                                                                                                                                                                                                                        |    |   |    |    |   |   |    |   |   |      |   |   |    |   |   |    |   |   |    |   |   |    |   |   |                                                                                                                                                                                                                                                                                                                                                                        |    |   |    |    |   |   |    |   |   |      |   |   |    |   |   |    |   |   |    |   |   |    |   |   |                                                                                                                                                                                                                                                                                                                                                                        |    |   |    |    |   |   |    |   |   |      |   |   |    |   |   |    |   |   |    |   |   |    |   |   |
| TERM   | 4                                                                                                                                                                                                                                                                                                                                                                      | ■      |                |                |    |   |   |    |   |   |      |   |   |    |   |   |    |   |   |    |   |   |    |   |   |                                                                                                                                                                                                                                                                                                                                                                        |    |   |    |    |   |   |    |   |   |      |   |   |    |   |   |    |   |   |    |   |   |    |   |   |                                                                                                                                                                                                                                                                                                                                                                        |    |   |    |    |   |   |    |   |   |      |   |   |    |   |   |    |   |   |    |   |   |    |   |   |                                                                                                                                                                                                                                                                                                                                                                        |    |   |    |    |   |   |    |   |   |      |   |   |    |   |   |    |   |   |    |   |   |    |   |   |
| T+     | 5                                                                                                                                                                                                                                                                                                                                                                      | ■      |                |                |    |   |   |    |   |   |      |   |   |    |   |   |    |   |   |    |   |   |    |   |   |                                                                                                                                                                                                                                                                                                                                                                        |    |   |    |    |   |   |    |   |   |      |   |   |    |   |   |    |   |   |    |   |   |    |   |   |                                                                                                                                                                                                                                                                                                                                                                        |    |   |    |    |   |   |    |   |   |      |   |   |    |   |   |    |   |   |    |   |   |    |   |   |                                                                                                                                                                                                                                                                                                                                                                        |    |   |    |    |   |   |    |   |   |      |   |   |    |   |   |    |   |   |    |   |   |    |   |   |
| T-     | 6                                                                                                                                                                                                                                                                                                                                                                      | ■      |                |                |    |   |   |    |   |   |      |   |   |    |   |   |    |   |   |    |   |   |    |   |   |                                                                                                                                                                                                                                                                                                                                                                        |    |   |    |    |   |   |    |   |   |      |   |   |    |   |   |    |   |   |    |   |   |    |   |   |                                                                                                                                                                                                                                                                                                                                                                        |    |   |    |    |   |   |    |   |   |      |   |   |    |   |   |    |   |   |    |   |   |    |   |   |                                                                                                                                                                                                                                                                                                                                                                        |    |   |    |    |   |   |    |   |   |      |   |   |    |   |   |    |   |   |    |   |   |    |   |   |
| R+     | 7                                                                                                                                                                                                                                                                                                                                                                      | ■      |                |                |    |   |   |    |   |   |      |   |   |    |   |   |    |   |   |    |   |   |    |   |   |                                                                                                                                                                                                                                                                                                                                                                        |    |   |    |    |   |   |    |   |   |      |   |   |    |   |   |    |   |   |    |   |   |    |   |   |                                                                                                                                                                                                                                                                                                                                                                        |    |   |    |    |   |   |    |   |   |      |   |   |    |   |   |    |   |   |    |   |   |    |   |   |                                                                                                                                                                                                                                                                                                                                                                        |    |   |    |    |   |   |    |   |   |      |   |   |    |   |   |    |   |   |    |   |   |    |   |   |
| R-     | 8                                                                                                                                                                                                                                                                                                                                                                      | ■      |                |                |    |   |   |    |   |   |      |   |   |    |   |   |    |   |   |    |   |   |    |   |   |                                                                                                                                                                                                                                                                                                                                                                        |    |   |    |    |   |   |    |   |   |      |   |   |    |   |   |    |   |   |    |   |   |    |   |   |                                                                                                                                                                                                                                                                                                                                                                        |    |   |    |    |   |   |    |   |   |      |   |   |    |   |   |    |   |   |    |   |   |    |   |   |                                                                                                                                                                                                                                                                                                                                                                        |    |   |    |    |   |   |    |   |   |      |   |   |    |   |   |    |   |   |    |   |   |    |   |   |
| M0     | 1                                                                                                                                                                                                                                                                                                                                                                      | ON     |                |                |    |   |   |    |   |   |      |   |   |    |   |   |    |   |   |    |   |   |    |   |   |                                                                                                                                                                                                                                                                                                                                                                        |    |   |    |    |   |   |    |   |   |      |   |   |    |   |   |    |   |   |    |   |   |    |   |   |                                                                                                                                                                                                                                                                                                                                                                        |    |   |    |    |   |   |    |   |   |      |   |   |    |   |   |    |   |   |    |   |   |    |   |   |                                                                                                                                                                                                                                                                                                                                                                        |    |   |    |    |   |   |    |   |   |      |   |   |    |   |   |    |   |   |    |   |   |    |   |   |
| M1     | 2                                                                                                                                                                                                                                                                                                                                                                      | ■      |                |                |    |   |   |    |   |   |      |   |   |    |   |   |    |   |   |    |   |   |    |   |   |                                                                                                                                                                                                                                                                                                                                                                        |    |   |    |    |   |   |    |   |   |      |   |   |    |   |   |    |   |   |    |   |   |    |   |   |                                                                                                                                                                                                                                                                                                                                                                        |    |   |    |    |   |   |    |   |   |      |   |   |    |   |   |    |   |   |    |   |   |    |   |   |                                                                                                                                                                                                                                                                                                                                                                        |    |   |    |    |   |   |    |   |   |      |   |   |    |   |   |    |   |   |    |   |   |    |   |   |
| M2     | 3                                                                                                                                                                                                                                                                                                                                                                      | ■      |                |                |    |   |   |    |   |   |      |   |   |    |   |   |    |   |   |    |   |   |    |   |   |                                                                                                                                                                                                                                                                                                                                                                        |    |   |    |    |   |   |    |   |   |      |   |   |    |   |   |    |   |   |    |   |   |    |   |   |                                                                                                                                                                                                                                                                                                                                                                        |    |   |    |    |   |   |    |   |   |      |   |   |    |   |   |    |   |   |    |   |   |    |   |   |                                                                                                                                                                                                                                                                                                                                                                        |    |   |    |    |   |   |    |   |   |      |   |   |    |   |   |    |   |   |    |   |   |    |   |   |
| TERM   | 4                                                                                                                                                                                                                                                                                                                                                                      | ■      |                |                |    |   |   |    |   |   |      |   |   |    |   |   |    |   |   |    |   |   |    |   |   |                                                                                                                                                                                                                                                                                                                                                                        |    |   |    |    |   |   |    |   |   |      |   |   |    |   |   |    |   |   |    |   |   |    |   |   |                                                                                                                                                                                                                                                                                                                                                                        |    |   |    |    |   |   |    |   |   |      |   |   |    |   |   |    |   |   |    |   |   |    |   |   |                                                                                                                                                                                                                                                                                                                                                                        |    |   |    |    |   |   |    |   |   |      |   |   |    |   |   |    |   |   |    |   |   |    |   |   |
| T+     | 5                                                                                                                                                                                                                                                                                                                                                                      | ■      |                |                |    |   |   |    |   |   |      |   |   |    |   |   |    |   |   |    |   |   |    |   |   |                                                                                                                                                                                                                                                                                                                                                                        |    |   |    |    |   |   |    |   |   |      |   |   |    |   |   |    |   |   |    |   |   |    |   |   |                                                                                                                                                                                                                                                                                                                                                                        |    |   |    |    |   |   |    |   |   |      |   |   |    |   |   |    |   |   |    |   |   |    |   |   |                                                                                                                                                                                                                                                                                                                                                                        |    |   |    |    |   |   |    |   |   |      |   |   |    |   |   |    |   |   |    |   |   |    |   |   |
| T-     | 6                                                                                                                                                                                                                                                                                                                                                                      | ■      |                |                |    |   |   |    |   |   |      |   |   |    |   |   |    |   |   |    |   |   |    |   |   |                                                                                                                                                                                                                                                                                                                                                                        |    |   |    |    |   |   |    |   |   |      |   |   |    |   |   |    |   |   |    |   |   |    |   |   |                                                                                                                                                                                                                                                                                                                                                                        |    |   |    |    |   |   |    |   |   |      |   |   |    |   |   |    |   |   |    |   |   |    |   |   |                                                                                                                                                                                                                                                                                                                                                                        |    |   |    |    |   |   |    |   |   |      |   |   |    |   |   |    |   |   |    |   |   |    |   |   |
| R+     | 7                                                                                                                                                                                                                                                                                                                                                                      | ■      |                |                |    |   |   |    |   |   |      |   |   |    |   |   |    |   |   |    |   |   |    |   |   |                                                                                                                                                                                                                                                                                                                                                                        |    |   |    |    |   |   |    |   |   |      |   |   |    |   |   |    |   |   |    |   |   |    |   |   |                                                                                                                                                                                                                                                                                                                                                                        |    |   |    |    |   |   |    |   |   |      |   |   |    |   |   |    |   |   |    |   |   |    |   |   |                                                                                                                                                                                                                                                                                                                                                                        |    |   |    |    |   |   |    |   |   |      |   |   |    |   |   |    |   |   |    |   |   |    |   |   |
| R-     | 8                                                                                                                                                                                                                                                                                                                                                                      | ■      |                |                |    |   |   |    |   |   |      |   |   |    |   |   |    |   |   |    |   |   |    |   |   |                                                                                                                                                                                                                                                                                                                                                                        |    |   |    |    |   |   |    |   |   |      |   |   |    |   |   |    |   |   |    |   |   |    |   |   |                                                                                                                                                                                                                                                                                                                                                                        |    |   |    |    |   |   |    |   |   |      |   |   |    |   |   |    |   |   |    |   |   |    |   |   |                                                                                                                                                                                                                                                                                                                                                                        |    |   |    |    |   |   |    |   |   |      |   |   |    |   |   |    |   |   |    |   |   |    |   |   |
| M0     | 1                                                                                                                                                                                                                                                                                                                                                                      | ON     |                |                |    |   |   |    |   |   |      |   |   |    |   |   |    |   |   |    |   |   |    |   |   |                                                                                                                                                                                                                                                                                                                                                                        |    |   |    |    |   |   |    |   |   |      |   |   |    |   |   |    |   |   |    |   |   |    |   |   |                                                                                                                                                                                                                                                                                                                                                                        |    |   |    |    |   |   |    |   |   |      |   |   |    |   |   |    |   |   |    |   |   |    |   |   |                                                                                                                                                                                                                                                                                                                                                                        |    |   |    |    |   |   |    |   |   |      |   |   |    |   |   |    |   |   |    |   |   |    |   |   |
| M1     | 2                                                                                                                                                                                                                                                                                                                                                                      | ■      |                |                |    |   |   |    |   |   |      |   |   |    |   |   |    |   |   |    |   |   |    |   |   |                                                                                                                                                                                                                                                                                                                                                                        |    |   |    |    |   |   |    |   |   |      |   |   |    |   |   |    |   |   |    |   |   |    |   |   |                                                                                                                                                                                                                                                                                                                                                                        |    |   |    |    |   |   |    |   |   |      |   |   |    |   |   |    |   |   |    |   |   |    |   |   |                                                                                                                                                                                                                                                                                                                                                                        |    |   |    |    |   |   |    |   |   |      |   |   |    |   |   |    |   |   |    |   |   |    |   |   |
| M2     | 3                                                                                                                                                                                                                                                                                                                                                                      | ■      |                |                |    |   |   |    |   |   |      |   |   |    |   |   |    |   |   |    |   |   |    |   |   |                                                                                                                                                                                                                                                                                                                                                                        |    |   |    |    |   |   |    |   |   |      |   |   |    |   |   |    |   |   |    |   |   |    |   |   |                                                                                                                                                                                                                                                                                                                                                                        |    |   |    |    |   |   |    |   |   |      |   |   |    |   |   |    |   |   |    |   |   |    |   |   |                                                                                                                                                                                                                                                                                                                                                                        |    |   |    |    |   |   |    |   |   |      |   |   |    |   |   |    |   |   |    |   |   |    |   |   |
| TERM   | 4                                                                                                                                                                                                                                                                                                                                                                      | ■      |                |                |    |   |   |    |   |   |      |   |   |    |   |   |    |   |   |    |   |   |    |   |   |                                                                                                                                                                                                                                                                                                                                                                        |    |   |    |    |   |   |    |   |   |      |   |   |    |   |   |    |   |   |    |   |   |    |   |   |                                                                                                                                                                                                                                                                                                                                                                        |    |   |    |    |   |   |    |   |   |      |   |   |    |   |   |    |   |   |    |   |   |    |   |   |                                                                                                                                                                                                                                                                                                                                                                        |    |   |    |    |   |   |    |   |   |      |   |   |    |   |   |    |   |   |    |   |   |    |   |   |
| T+     | 5                                                                                                                                                                                                                                                                                                                                                                      | ■      |                |                |    |   |   |    |   |   |      |   |   |    |   |   |    |   |   |    |   |   |    |   |   |                                                                                                                                                                                                                                                                                                                                                                        |    |   |    |    |   |   |    |   |   |      |   |   |    |   |   |    |   |   |    |   |   |    |   |   |                                                                                                                                                                                                                                                                                                                                                                        |    |   |    |    |   |   |    |   |   |      |   |   |    |   |   |    |   |   |    |   |   |    |   |   |                                                                                                                                                                                                                                                                                                                                                                        |    |   |    |    |   |   |    |   |   |      |   |   |    |   |   |    |   |   |    |   |   |    |   |   |
| T-     | 6                                                                                                                                                                                                                                                                                                                                                                      | ■      |                |                |    |   |   |    |   |   |      |   |   |    |   |   |    |   |   |    |   |   |    |   |   |                                                                                                                                                                                                                                                                                                                                                                        |    |   |    |    |   |   |    |   |   |      |   |   |    |   |   |    |   |   |    |   |   |    |   |   |                                                                                                                                                                                                                                                                                                                                                                        |    |   |    |    |   |   |    |   |   |      |   |   |    |   |   |    |   |   |    |   |   |    |   |   |                                                                                                                                                                                                                                                                                                                                                                        |    |   |    |    |   |   |    |   |   |      |   |   |    |   |   |    |   |   |    |   |   |    |   |   |
| R+     | 7                                                                                                                                                                                                                                                                                                                                                                      | ■      |                |                |    |   |   |    |   |   |      |   |   |    |   |   |    |   |   |    |   |   |    |   |   |                                                                                                                                                                                                                                                                                                                                                                        |    |   |    |    |   |   |    |   |   |      |   |   |    |   |   |    |   |   |    |   |   |    |   |   |                                                                                                                                                                                                                                                                                                                                                                        |    |   |    |    |   |   |    |   |   |      |   |   |    |   |   |    |   |   |    |   |   |    |   |   |                                                                                                                                                                                                                                                                                                                                                                        |    |   |    |    |   |   |    |   |   |      |   |   |    |   |   |    |   |   |    |   |   |    |   |   |
| R-     | 8                                                                                                                                                                                                                                                                                                                                                                      | ■      |                |                |    |   |   |    |   |   |      |   |   |    |   |   |    |   |   |    |   |   |    |   |   |                                                                                                                                                                                                                                                                                                                                                                        |    |   |    |    |   |   |    |   |   |      |   |   |    |   |   |    |   |   |    |   |   |    |   |   |                                                                                                                                                                                                                                                                                                                                                                        |    |   |    |    |   |   |    |   |   |      |   |   |    |   |   |    |   |   |    |   |   |    |   |   |                                                                                                                                                                                                                                                                                                                                                                        |    |   |    |    |   |   |    |   |   |      |   |   |    |   |   |    |   |   |    |   |   |    |   |   |
| Port 4 | <table border="1"> <tr><td>M0</td><td>1</td><td>ON</td></tr> <tr><td>M1</td><td>2</td><td>■</td></tr> <tr><td>M2</td><td>3</td><td>■</td></tr> <tr><td>TERM</td><td>4</td><td>■</td></tr> <tr><td>T+</td><td>5</td><td>■</td></tr> <tr><td>T-</td><td>6</td><td>■</td></tr> <tr><td>R+</td><td>7</td><td>■</td></tr> <tr><td>R-</td><td>8</td><td>■</td></tr> </table> | M0     | 1              | ON             | M1 | 2 | ■ | M2 | 3 | ■ | TERM | 4 | ■ | T+ | 5 | ■ | T- | 6 | ■ | R+ | 7 | ■ | R- | 8 | ■ | <table border="1"> <tr><td>M0</td><td>1</td><td>ON</td></tr> <tr><td>M1</td><td>2</td><td>■</td></tr> <tr><td>M2</td><td>3</td><td>■</td></tr> <tr><td>TERM</td><td>4</td><td>■</td></tr> <tr><td>T+</td><td>5</td><td>■</td></tr> <tr><td>T-</td><td>6</td><td>■</td></tr> <tr><td>R+</td><td>7</td><td>■</td></tr> <tr><td>R-</td><td>8</td><td>■</td></tr> </table> | M0 | 1 | ON | M1 | 2 | ■ | M2 | 3 | ■ | TERM | 4 | ■ | T+ | 5 | ■ | T- | 6 | ■ | R+ | 7 | ■ | R- | 8 | ■ | <table border="1"> <tr><td>M0</td><td>1</td><td>ON</td></tr> <tr><td>M1</td><td>2</td><td>■</td></tr> <tr><td>M2</td><td>3</td><td>■</td></tr> <tr><td>TERM</td><td>4</td><td>■</td></tr> <tr><td>T+</td><td>5</td><td>■</td></tr> <tr><td>T-</td><td>6</td><td>■</td></tr> <tr><td>R+</td><td>7</td><td>■</td></tr> <tr><td>R-</td><td>8</td><td>■</td></tr> </table> | M0 | 1 | ON | M1 | 2 | ■ | M2 | 3 | ■ | TERM | 4 | ■ | T+ | 5 | ■ | T- | 6 | ■ | R+ | 7 | ■ | R- | 8 | ■ | <table border="1"> <tr><td>M0</td><td>1</td><td>ON</td></tr> <tr><td>M1</td><td>2</td><td>■</td></tr> <tr><td>M2</td><td>3</td><td>■</td></tr> <tr><td>TERM</td><td>4</td><td>■</td></tr> <tr><td>T+</td><td>5</td><td>■</td></tr> <tr><td>T-</td><td>6</td><td>■</td></tr> <tr><td>R+</td><td>7</td><td>■</td></tr> <tr><td>R-</td><td>8</td><td>■</td></tr> </table> | M0 | 1 | ON | M1 | 2 | ■ | M2 | 3 | ■ | TERM | 4 | ■ | T+ | 5 | ■ | T- | 6 | ■ | R+ | 7 | ■ | R- | 8 | ■ |
| M0     | 1                                                                                                                                                                                                                                                                                                                                                                      | ON     |                |                |    |   |   |    |   |   |      |   |   |    |   |   |    |   |   |    |   |   |    |   |   |                                                                                                                                                                                                                                                                                                                                                                        |    |   |    |    |   |   |    |   |   |      |   |   |    |   |   |    |   |   |    |   |   |    |   |   |                                                                                                                                                                                                                                                                                                                                                                        |    |   |    |    |   |   |    |   |   |      |   |   |    |   |   |    |   |   |    |   |   |    |   |   |                                                                                                                                                                                                                                                                                                                                                                        |    |   |    |    |   |   |    |   |   |      |   |   |    |   |   |    |   |   |    |   |   |    |   |   |
| M1     | 2                                                                                                                                                                                                                                                                                                                                                                      | ■      |                |                |    |   |   |    |   |   |      |   |   |    |   |   |    |   |   |    |   |   |    |   |   |                                                                                                                                                                                                                                                                                                                                                                        |    |   |    |    |   |   |    |   |   |      |   |   |    |   |   |    |   |   |    |   |   |    |   |   |                                                                                                                                                                                                                                                                                                                                                                        |    |   |    |    |   |   |    |   |   |      |   |   |    |   |   |    |   |   |    |   |   |    |   |   |                                                                                                                                                                                                                                                                                                                                                                        |    |   |    |    |   |   |    |   |   |      |   |   |    |   |   |    |   |   |    |   |   |    |   |   |
| M2     | 3                                                                                                                                                                                                                                                                                                                                                                      | ■      |                |                |    |   |   |    |   |   |      |   |   |    |   |   |    |   |   |    |   |   |    |   |   |                                                                                                                                                                                                                                                                                                                                                                        |    |   |    |    |   |   |    |   |   |      |   |   |    |   |   |    |   |   |    |   |   |    |   |   |                                                                                                                                                                                                                                                                                                                                                                        |    |   |    |    |   |   |    |   |   |      |   |   |    |   |   |    |   |   |    |   |   |    |   |   |                                                                                                                                                                                                                                                                                                                                                                        |    |   |    |    |   |   |    |   |   |      |   |   |    |   |   |    |   |   |    |   |   |    |   |   |
| TERM   | 4                                                                                                                                                                                                                                                                                                                                                                      | ■      |                |                |    |   |   |    |   |   |      |   |   |    |   |   |    |   |   |    |   |   |    |   |   |                                                                                                                                                                                                                                                                                                                                                                        |    |   |    |    |   |   |    |   |   |      |   |   |    |   |   |    |   |   |    |   |   |    |   |   |                                                                                                                                                                                                                                                                                                                                                                        |    |   |    |    |   |   |    |   |   |      |   |   |    |   |   |    |   |   |    |   |   |    |   |   |                                                                                                                                                                                                                                                                                                                                                                        |    |   |    |    |   |   |    |   |   |      |   |   |    |   |   |    |   |   |    |   |   |    |   |   |
| T+     | 5                                                                                                                                                                                                                                                                                                                                                                      | ■      |                |                |    |   |   |    |   |   |      |   |   |    |   |   |    |   |   |    |   |   |    |   |   |                                                                                                                                                                                                                                                                                                                                                                        |    |   |    |    |   |   |    |   |   |      |   |   |    |   |   |    |   |   |    |   |   |    |   |   |                                                                                                                                                                                                                                                                                                                                                                        |    |   |    |    |   |   |    |   |   |      |   |   |    |   |   |    |   |   |    |   |   |    |   |   |                                                                                                                                                                                                                                                                                                                                                                        |    |   |    |    |   |   |    |   |   |      |   |   |    |   |   |    |   |   |    |   |   |    |   |   |
| T-     | 6                                                                                                                                                                                                                                                                                                                                                                      | ■      |                |                |    |   |   |    |   |   |      |   |   |    |   |   |    |   |   |    |   |   |    |   |   |                                                                                                                                                                                                                                                                                                                                                                        |    |   |    |    |   |   |    |   |   |      |   |   |    |   |   |    |   |   |    |   |   |    |   |   |                                                                                                                                                                                                                                                                                                                                                                        |    |   |    |    |   |   |    |   |   |      |   |   |    |   |   |    |   |   |    |   |   |    |   |   |                                                                                                                                                                                                                                                                                                                                                                        |    |   |    |    |   |   |    |   |   |      |   |   |    |   |   |    |   |   |    |   |   |    |   |   |
| R+     | 7                                                                                                                                                                                                                                                                                                                                                                      | ■      |                |                |    |   |   |    |   |   |      |   |   |    |   |   |    |   |   |    |   |   |    |   |   |                                                                                                                                                                                                                                                                                                                                                                        |    |   |    |    |   |   |    |   |   |      |   |   |    |   |   |    |   |   |    |   |   |    |   |   |                                                                                                                                                                                                                                                                                                                                                                        |    |   |    |    |   |   |    |   |   |      |   |   |    |   |   |    |   |   |    |   |   |    |   |   |                                                                                                                                                                                                                                                                                                                                                                        |    |   |    |    |   |   |    |   |   |      |   |   |    |   |   |    |   |   |    |   |   |    |   |   |
| R-     | 8                                                                                                                                                                                                                                                                                                                                                                      | ■      |                |                |    |   |   |    |   |   |      |   |   |    |   |   |    |   |   |    |   |   |    |   |   |                                                                                                                                                                                                                                                                                                                                                                        |    |   |    |    |   |   |    |   |   |      |   |   |    |   |   |    |   |   |    |   |   |    |   |   |                                                                                                                                                                                                                                                                                                                                                                        |    |   |    |    |   |   |    |   |   |      |   |   |    |   |   |    |   |   |    |   |   |    |   |   |                                                                                                                                                                                                                                                                                                                                                                        |    |   |    |    |   |   |    |   |   |      |   |   |    |   |   |    |   |   |    |   |   |    |   |   |
| M0     | 1                                                                                                                                                                                                                                                                                                                                                                      | ON     |                |                |    |   |   |    |   |   |      |   |   |    |   |   |    |   |   |    |   |   |    |   |   |                                                                                                                                                                                                                                                                                                                                                                        |    |   |    |    |   |   |    |   |   |      |   |   |    |   |   |    |   |   |    |   |   |    |   |   |                                                                                                                                                                                                                                                                                                                                                                        |    |   |    |    |   |   |    |   |   |      |   |   |    |   |   |    |   |   |    |   |   |    |   |   |                                                                                                                                                                                                                                                                                                                                                                        |    |   |    |    |   |   |    |   |   |      |   |   |    |   |   |    |   |   |    |   |   |    |   |   |
| M1     | 2                                                                                                                                                                                                                                                                                                                                                                      | ■      |                |                |    |   |   |    |   |   |      |   |   |    |   |   |    |   |   |    |   |   |    |   |   |                                                                                                                                                                                                                                                                                                                                                                        |    |   |    |    |   |   |    |   |   |      |   |   |    |   |   |    |   |   |    |   |   |    |   |   |                                                                                                                                                                                                                                                                                                                                                                        |    |   |    |    |   |   |    |   |   |      |   |   |    |   |   |    |   |   |    |   |   |    |   |   |                                                                                                                                                                                                                                                                                                                                                                        |    |   |    |    |   |   |    |   |   |      |   |   |    |   |   |    |   |   |    |   |   |    |   |   |
| M2     | 3                                                                                                                                                                                                                                                                                                                                                                      | ■      |                |                |    |   |   |    |   |   |      |   |   |    |   |   |    |   |   |    |   |   |    |   |   |                                                                                                                                                                                                                                                                                                                                                                        |    |   |    |    |   |   |    |   |   |      |   |   |    |   |   |    |   |   |    |   |   |    |   |   |                                                                                                                                                                                                                                                                                                                                                                        |    |   |    |    |   |   |    |   |   |      |   |   |    |   |   |    |   |   |    |   |   |    |   |   |                                                                                                                                                                                                                                                                                                                                                                        |    |   |    |    |   |   |    |   |   |      |   |   |    |   |   |    |   |   |    |   |   |    |   |   |
| TERM   | 4                                                                                                                                                                                                                                                                                                                                                                      | ■      |                |                |    |   |   |    |   |   |      |   |   |    |   |   |    |   |   |    |   |   |    |   |   |                                                                                                                                                                                                                                                                                                                                                                        |    |   |    |    |   |   |    |   |   |      |   |   |    |   |   |    |   |   |    |   |   |    |   |   |                                                                                                                                                                                                                                                                                                                                                                        |    |   |    |    |   |   |    |   |   |      |   |   |    |   |   |    |   |   |    |   |   |    |   |   |                                                                                                                                                                                                                                                                                                                                                                        |    |   |    |    |   |   |    |   |   |      |   |   |    |   |   |    |   |   |    |   |   |    |   |   |
| T+     | 5                                                                                                                                                                                                                                                                                                                                                                      | ■      |                |                |    |   |   |    |   |   |      |   |   |    |   |   |    |   |   |    |   |   |    |   |   |                                                                                                                                                                                                                                                                                                                                                                        |    |   |    |    |   |   |    |   |   |      |   |   |    |   |   |    |   |   |    |   |   |    |   |   |                                                                                                                                                                                                                                                                                                                                                                        |    |   |    |    |   |   |    |   |   |      |   |   |    |   |   |    |   |   |    |   |   |    |   |   |                                                                                                                                                                                                                                                                                                                                                                        |    |   |    |    |   |   |    |   |   |      |   |   |    |   |   |    |   |   |    |   |   |    |   |   |
| T-     | 6                                                                                                                                                                                                                                                                                                                                                                      | ■      |                |                |    |   |   |    |   |   |      |   |   |    |   |   |    |   |   |    |   |   |    |   |   |                                                                                                                                                                                                                                                                                                                                                                        |    |   |    |    |   |   |    |   |   |      |   |   |    |   |   |    |   |   |    |   |   |    |   |   |                                                                                                                                                                                                                                                                                                                                                                        |    |   |    |    |   |   |    |   |   |      |   |   |    |   |   |    |   |   |    |   |   |    |   |   |                                                                                                                                                                                                                                                                                                                                                                        |    |   |    |    |   |   |    |   |   |      |   |   |    |   |   |    |   |   |    |   |   |    |   |   |
| R+     | 7                                                                                                                                                                                                                                                                                                                                                                      | ■      |                |                |    |   |   |    |   |   |      |   |   |    |   |   |    |   |   |    |   |   |    |   |   |                                                                                                                                                                                                                                                                                                                                                                        |    |   |    |    |   |   |    |   |   |      |   |   |    |   |   |    |   |   |    |   |   |    |   |   |                                                                                                                                                                                                                                                                                                                                                                        |    |   |    |    |   |   |    |   |   |      |   |   |    |   |   |    |   |   |    |   |   |    |   |   |                                                                                                                                                                                                                                                                                                                                                                        |    |   |    |    |   |   |    |   |   |      |   |   |    |   |   |    |   |   |    |   |   |    |   |   |
| R-     | 8                                                                                                                                                                                                                                                                                                                                                                      | ■      |                |                |    |   |   |    |   |   |      |   |   |    |   |   |    |   |   |    |   |   |    |   |   |                                                                                                                                                                                                                                                                                                                                                                        |    |   |    |    |   |   |    |   |   |      |   |   |    |   |   |    |   |   |    |   |   |    |   |   |                                                                                                                                                                                                                                                                                                                                                                        |    |   |    |    |   |   |    |   |   |      |   |   |    |   |   |    |   |   |    |   |   |    |   |   |                                                                                                                                                                                                                                                                                                                                                                        |    |   |    |    |   |   |    |   |   |      |   |   |    |   |   |    |   |   |    |   |   |    |   |   |
| M0     | 1                                                                                                                                                                                                                                                                                                                                                                      | ON     |                |                |    |   |   |    |   |   |      |   |   |    |   |   |    |   |   |    |   |   |    |   |   |                                                                                                                                                                                                                                                                                                                                                                        |    |   |    |    |   |   |    |   |   |      |   |   |    |   |   |    |   |   |    |   |   |    |   |   |                                                                                                                                                                                                                                                                                                                                                                        |    |   |    |    |   |   |    |   |   |      |   |   |    |   |   |    |   |   |    |   |   |    |   |   |                                                                                                                                                                                                                                                                                                                                                                        |    |   |    |    |   |   |    |   |   |      |   |   |    |   |   |    |   |   |    |   |   |    |   |   |
| M1     | 2                                                                                                                                                                                                                                                                                                                                                                      | ■      |                |                |    |   |   |    |   |   |      |   |   |    |   |   |    |   |   |    |   |   |    |   |   |                                                                                                                                                                                                                                                                                                                                                                        |    |   |    |    |   |   |    |   |   |      |   |   |    |   |   |    |   |   |    |   |   |    |   |   |                                                                                                                                                                                                                                                                                                                                                                        |    |   |    |    |   |   |    |   |   |      |   |   |    |   |   |    |   |   |    |   |   |    |   |   |                                                                                                                                                                                                                                                                                                                                                                        |    |   |    |    |   |   |    |   |   |      |   |   |    |   |   |    |   |   |    |   |   |    |   |   |
| M2     | 3                                                                                                                                                                                                                                                                                                                                                                      | ■      |                |                |    |   |   |    |   |   |      |   |   |    |   |   |    |   |   |    |   |   |    |   |   |                                                                                                                                                                                                                                                                                                                                                                        |    |   |    |    |   |   |    |   |   |      |   |   |    |   |   |    |   |   |    |   |   |    |   |   |                                                                                                                                                                                                                                                                                                                                                                        |    |   |    |    |   |   |    |   |   |      |   |   |    |   |   |    |   |   |    |   |   |    |   |   |                                                                                                                                                                                                                                                                                                                                                                        |    |   |    |    |   |   |    |   |   |      |   |   |    |   |   |    |   |   |    |   |   |    |   |   |
| TERM   | 4                                                                                                                                                                                                                                                                                                                                                                      | ■      |                |                |    |   |   |    |   |   |      |   |   |    |   |   |    |   |   |    |   |   |    |   |   |                                                                                                                                                                                                                                                                                                                                                                        |    |   |    |    |   |   |    |   |   |      |   |   |    |   |   |    |   |   |    |   |   |    |   |   |                                                                                                                                                                                                                                                                                                                                                                        |    |   |    |    |   |   |    |   |   |      |   |   |    |   |   |    |   |   |    |   |   |    |   |   |                                                                                                                                                                                                                                                                                                                                                                        |    |   |    |    |   |   |    |   |   |      |   |   |    |   |   |    |   |   |    |   |   |    |   |   |
| T+     | 5                                                                                                                                                                                                                                                                                                                                                                      | ■      |                |                |    |   |   |    |   |   |      |   |   |    |   |   |    |   |   |    |   |   |    |   |   |                                                                                                                                                                                                                                                                                                                                                                        |    |   |    |    |   |   |    |   |   |      |   |   |    |   |   |    |   |   |    |   |   |    |   |   |                                                                                                                                                                                                                                                                                                                                                                        |    |   |    |    |   |   |    |   |   |      |   |   |    |   |   |    |   |   |    |   |   |    |   |   |                                                                                                                                                                                                                                                                                                                                                                        |    |   |    |    |   |   |    |   |   |      |   |   |    |   |   |    |   |   |    |   |   |    |   |   |
| T-     | 6                                                                                                                                                                                                                                                                                                                                                                      | ■      |                |                |    |   |   |    |   |   |      |   |   |    |   |   |    |   |   |    |   |   |    |   |   |                                                                                                                                                                                                                                                                                                                                                                        |    |   |    |    |   |   |    |   |   |      |   |   |    |   |   |    |   |   |    |   |   |    |   |   |                                                                                                                                                                                                                                                                                                                                                                        |    |   |    |    |   |   |    |   |   |      |   |   |    |   |   |    |   |   |    |   |   |    |   |   |                                                                                                                                                                                                                                                                                                                                                                        |    |   |    |    |   |   |    |   |   |      |   |   |    |   |   |    |   |   |    |   |   |    |   |   |
| R+     | 7                                                                                                                                                                                                                                                                                                                                                                      | ■      |                |                |    |   |   |    |   |   |      |   |   |    |   |   |    |   |   |    |   |   |    |   |   |                                                                                                                                                                                                                                                                                                                                                                        |    |   |    |    |   |   |    |   |   |      |   |   |    |   |   |    |   |   |    |   |   |    |   |   |                                                                                                                                                                                                                                                                                                                                                                        |    |   |    |    |   |   |    |   |   |      |   |   |    |   |   |    |   |   |    |   |   |    |   |   |                                                                                                                                                                                                                                                                                                                                                                        |    |   |    |    |   |   |    |   |   |      |   |   |    |   |   |    |   |   |    |   |   |    |   |   |
| R-     | 8                                                                                                                                                                                                                                                                                                                                                                      | ■      |                |                |    |   |   |    |   |   |      |   |   |    |   |   |    |   |   |    |   |   |    |   |   |                                                                                                                                                                                                                                                                                                                                                                        |    |   |    |    |   |   |    |   |   |      |   |   |    |   |   |    |   |   |    |   |   |    |   |   |                                                                                                                                                                                                                                                                                                                                                                        |    |   |    |    |   |   |    |   |   |      |   |   |    |   |   |    |   |   |    |   |   |    |   |   |                                                                                                                                                                                                                                                                                                                                                                        |    |   |    |    |   |   |    |   |   |      |   |   |    |   |   |    |   |   |    |   |   |    |   |   |
| M0     | 1                                                                                                                                                                                                                                                                                                                                                                      | ON     |                |                |    |   |   |    |   |   |      |   |   |    |   |   |    |   |   |    |   |   |    |   |   |                                                                                                                                                                                                                                                                                                                                                                        |    |   |    |    |   |   |    |   |   |      |   |   |    |   |   |    |   |   |    |   |   |    |   |   |                                                                                                                                                                                                                                                                                                                                                                        |    |   |    |    |   |   |    |   |   |      |   |   |    |   |   |    |   |   |    |   |   |    |   |   |                                                                                                                                                                                                                                                                                                                                                                        |    |   |    |    |   |   |    |   |   |      |   |   |    |   |   |    |   |   |    |   |   |    |   |   |
| M1     | 2                                                                                                                                                                                                                                                                                                                                                                      | ■      |                |                |    |   |   |    |   |   |      |   |   |    |   |   |    |   |   |    |   |   |    |   |   |                                                                                                                                                                                                                                                                                                                                                                        |    |   |    |    |   |   |    |   |   |      |   |   |    |   |   |    |   |   |    |   |   |    |   |   |                                                                                                                                                                                                                                                                                                                                                                        |    |   |    |    |   |   |    |   |   |      |   |   |    |   |   |    |   |   |    |   |   |    |   |   |                                                                                                                                                                                                                                                                                                                                                                        |    |   |    |    |   |   |    |   |   |      |   |   |    |   |   |    |   |   |    |   |   |    |   |   |
| M2     | 3                                                                                                                                                                                                                                                                                                                                                                      | ■      |                |                |    |   |   |    |   |   |      |   |   |    |   |   |    |   |   |    |   |   |    |   |   |                                                                                                                                                                                                                                                                                                                                                                        |    |   |    |    |   |   |    |   |   |      |   |   |    |   |   |    |   |   |    |   |   |    |   |   |                                                                                                                                                                                                                                                                                                                                                                        |    |   |    |    |   |   |    |   |   |      |   |   |    |   |   |    |   |   |    |   |   |    |   |   |                                                                                                                                                                                                                                                                                                                                                                        |    |   |    |    |   |   |    |   |   |      |   |   |    |   |   |    |   |   |    |   |   |    |   |   |
| TERM   | 4                                                                                                                                                                                                                                                                                                                                                                      | ■      |                |                |    |   |   |    |   |   |      |   |   |    |   |   |    |   |   |    |   |   |    |   |   |                                                                                                                                                                                                                                                                                                                                                                        |    |   |    |    |   |   |    |   |   |      |   |   |    |   |   |    |   |   |    |   |   |    |   |   |                                                                                                                                                                                                                                                                                                                                                                        |    |   |    |    |   |   |    |   |   |      |   |   |    |   |   |    |   |   |    |   |   |    |   |   |                                                                                                                                                                                                                                                                                                                                                                        |    |   |    |    |   |   |    |   |   |      |   |   |    |   |   |    |   |   |    |   |   |    |   |   |
| T+     | 5                                                                                                                                                                                                                                                                                                                                                                      | ■      |                |                |    |   |   |    |   |   |      |   |   |    |   |   |    |   |   |    |   |   |    |   |   |                                                                                                                                                                                                                                                                                                                                                                        |    |   |    |    |   |   |    |   |   |      |   |   |    |   |   |    |   |   |    |   |   |    |   |   |                                                                                                                                                                                                                                                                                                                                                                        |    |   |    |    |   |   |    |   |   |      |   |   |    |   |   |    |   |   |    |   |   |    |   |   |                                                                                                                                                                                                                                                                                                                                                                        |    |   |    |    |   |   |    |   |   |      |   |   |    |   |   |    |   |   |    |   |   |    |   |   |
| T-     | 6                                                                                                                                                                                                                                                                                                                                                                      | ■      |                |                |    |   |   |    |   |   |      |   |   |    |   |   |    |   |   |    |   |   |    |   |   |                                                                                                                                                                                                                                                                                                                                                                        |    |   |    |    |   |   |    |   |   |      |   |   |    |   |   |    |   |   |    |   |   |    |   |   |                                                                                                                                                                                                                                                                                                                                                                        |    |   |    |    |   |   |    |   |   |      |   |   |    |   |   |    |   |   |    |   |   |    |   |   |                                                                                                                                                                                                                                                                                                                                                                        |    |   |    |    |   |   |    |   |   |      |   |   |    |   |   |    |   |   |    |   |   |    |   |   |
| R+     | 7                                                                                                                                                                                                                                                                                                                                                                      | ■      |                |                |    |   |   |    |   |   |      |   |   |    |   |   |    |   |   |    |   |   |    |   |   |                                                                                                                                                                                                                                                                                                                                                                        |    |   |    |    |   |   |    |   |   |      |   |   |    |   |   |    |   |   |    |   |   |    |   |   |                                                                                                                                                                                                                                                                                                                                                                        |    |   |    |    |   |   |    |   |   |      |   |   |    |   |   |    |   |   |    |   |   |    |   |   |                                                                                                                                                                                                                                                                                                                                                                        |    |   |    |    |   |   |    |   |   |      |   |   |    |   |   |    |   |   |    |   |   |    |   |   |
| R-     | 8                                                                                                                                                                                                                                                                                                                                                                      | ■      |                |                |    |   |   |    |   |   |      |   |   |    |   |   |    |   |   |    |   |   |    |   |   |                                                                                                                                                                                                                                                                                                                                                                        |    |   |    |    |   |   |    |   |   |      |   |   |    |   |   |    |   |   |    |   |   |    |   |   |                                                                                                                                                                                                                                                                                                                                                                        |    |   |    |    |   |   |    |   |   |      |   |   |    |   |   |    |   |   |    |   |   |    |   |   |                                                                                                                                                                                                                                                                                                                                                                        |    |   |    |    |   |   |    |   |   |      |   |   |    |   |   |    |   |   |    |   |   |    |   |   |

## 4. Switch Einstellungen

### Mode & Terminator Switch (S1-S4\_Mode)

Resistoren Off

|      |   |    |
|------|---|----|
| M0   | 1 | ON |
| M1   | 2 |    |
| M2   | 3 |    |
| TERM | 4 |    |
| T+   | 5 | ■  |
| T-   | 6 | ■  |
| R+   | 7 | ■  |
| R-   | 8 | ■  |

Resistoren On

|      |   |    |
|------|---|----|
| M0   | 1 | ON |
| M1   | 2 |    |
| M2   | 3 |    |
| TERM | 4 |    |
| T+   | 5 | ■  |
| T-   | 6 | ■  |
| R+   | 7 | ■  |
| R-   | 8 | ■  |

Terminator Off

|      |   |    |
|------|---|----|
| M0   | 1 | ON |
| M1   | 2 |    |
| M2   | 3 |    |
| TERM | 4 | ■  |
| T+   | 5 |    |
| T-   | 6 |    |
| R+   | 7 |    |
| R-   | 8 |    |

Terminator On

|      |   |    |
|------|---|----|
| M0   | 1 | ON |
| M1   | 2 |    |
| M2   | 3 |    |
| TERM | 4 | ■  |
| T+   | 5 |    |
| T-   | 6 |    |
| R+   | 7 |    |
| R-   | 8 |    |

### Resistoren für RS-422, RS-485 2-Draht und RS-485 4-Draht Mode:

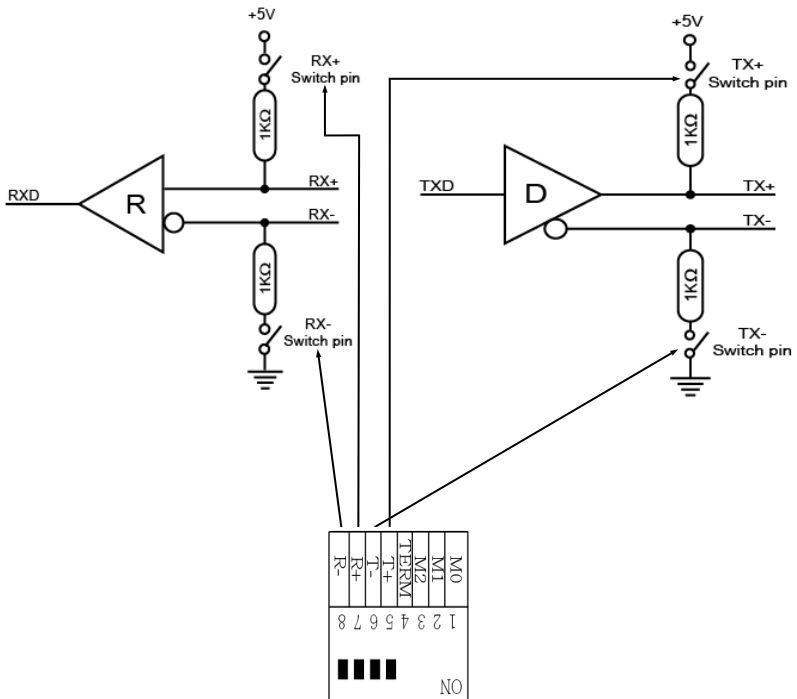

# 4. Switch Einstellungen

Terminator für RS-422, RS-485 2-Draht und RS-485 4-Draht Mode:

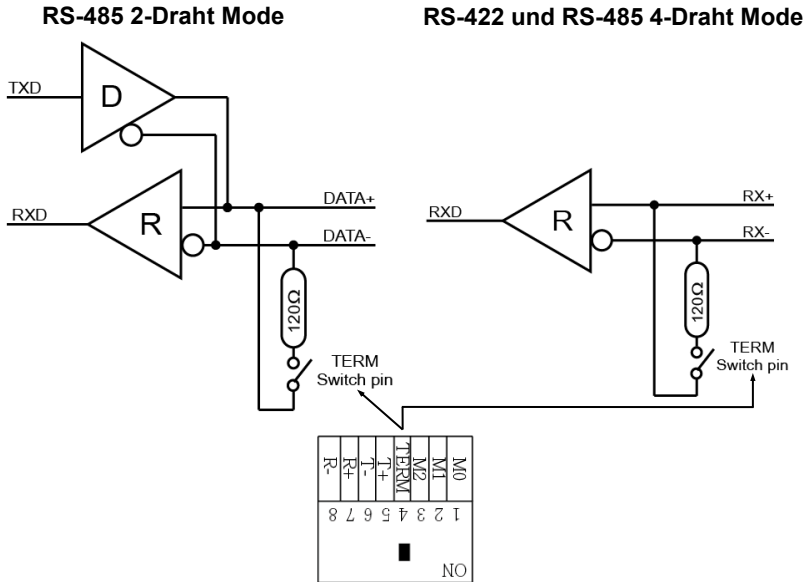



## 5. Hardware Installation

Wenn Sie die Karte installieren, beachten Sie bitte die folgenden Hinweise. Da es große Unterschiede zwischen PC's gibt, können wir Ihnen nur eine generelle Anleitung zum Einbau der EX-45034IS geben. Bei Unklarheiten halten Sie sich bitte an die Bedienungsanleitung Ihres Computersystems.

1. Schalten Sie Ihren Rechner und alle angeschlossenen Peripheriegeräte aus und ziehen Sie bei allen Geräten den Netzstecker.
2. Lösen Sie die Schrauben des Gehäuses auf der Rückseite Ihres Computers und entfernen Sie vorsichtig das Gehäuse.
3. Suchen Sie einen freien PCI-Express Steckplatz und stecken Sie die Karte vorsichtig in den ausgewählten PCI-Express Steckplatz ein. Stellen Sie sicher das es sich um den richtigen Steckplatz handelt!
4. Beachten Sie das die Karte korrekt eingesteckt wird und das kein Kurzschluss entsteht. Wenden Sie bitte keine Gewalt an um die Karte einzustecken!
5. Installieren Sie als erstes die beiden 2x 9 Pin Bügel an den internen seriellen 10 Pin Header S3 & S4.
6. Danach befestigen Sie die Karte bitte mit einer Schraube am Gehäuse.
7. Jetzt können Sie das Computergehäuse mit den Schrauben wieder schließen.

## 6. Treiber Installation

### Windows

Nach Abschluss der Hardwareinstallation erkennt das Betriebssystem automatisch die Karte und installiert diese! Falls die Treiber nicht automatisch installiert werden sollten, müssen Sie nun manuell zwei Treiber installieren. Zum einen den USB Host Treiber und zum anderen den USB zu seriell Treiber. Legen Sie hierfür die Treiber CD in Ihr CD-ROM Laufwerk (z.B. Laufwerk D:) ein und starten Sie das „**SETUP**“ welches sich im Ordner „uPD720201\_202“ befindet (siehe Abbildung): Folgen Sie den Installationsanweisungen und schließen Sie die Installation ab. **Wichtig!** Starten Sie Ihren PC nach der Installation neu.

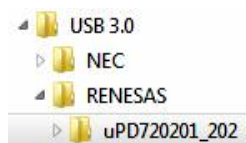

## 6. Treiber Installation

### Windows

Als zweites installieren Sie jetzt den USB zu seriell Treiber. Nun öffnen Sie den Ordner „USB\_to\_IO/FTDI“. Nun wählen Sie den Ordner Ihres Betriebssystems aus und installieren Sie die Treiber (siehe Abbildung). Folgen Sie den Installationsanweisungen und schließen Sie die Installation ab. **Wichtig!** Starten Sie Ihren PC nach der Installation neu.

Es werden folgende Treiber für die Server Betriebssysteme installiert:

|                       |   |                     |
|-----------------------|---|---------------------|
| Windows Server 2003   | = | XP Treiber          |
| Windows Server 2008   | = | VISTA Treiber       |
| Windows Server 2008R2 | = | Windows 7 Treiber   |
| Windows Server 2012   | = | Windows 8.x Treiber |
| Windows Server 2012R2 | = | Windows 10 Treiber  |

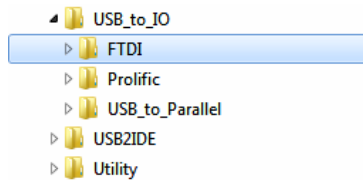

### ÜBERPRÜFEN DES INSTALLIERTEN TREIBER

Öffnen Sie den **>Geräte-Manager<**. Jetzt müssten Sie unter **„Anschlüsse (COM & LPT)“** und unter **„USB-Controller“** folgende Einträge sehen:

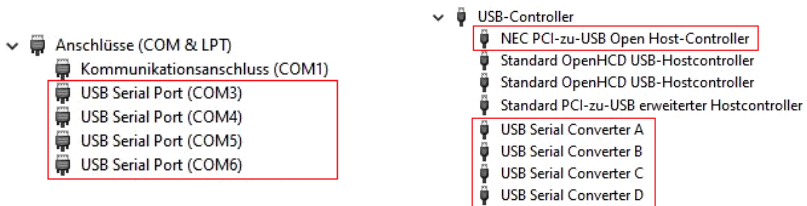

Sind diese oder ähnliche Einträge vorhanden, ist die Karte richtig installiert.

### ÄNDERN DER PORT NUMMER

Sie können auch die Port Nummer ändern, indem Sie im Gerätemanager z.B. **„COM3“** **„Anschlusseinstellung“** und **„Erweitert“** öffnen. Nun können Sie dann zwischen COM3 bis COM256 wählen!

## 6. Treiber Installation

### Linux & Mac OS

Die Treiber für Linux & Mac OS Systeme befinden sich ebenfalls im Ordner „USB\_to\_IO/FTDI“. Nun wählen Sie den Ordner Ihres Betriebssystems aus und installieren Sie die Treiber (siehe Abbildung).

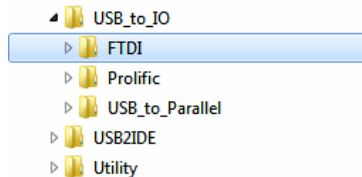

Da sich die einzelnen Distributionen und Kernelversionen sehr voneinander unterscheiden, können wir Ihnen leider keine Installationsanweisung zu Verfügung stellen. Bitte halten Sie sich an die Installationsanweisung für Standard I/O Ports Ihrer Linux/Unix oder Mac OS Version. In einigen neueren Versionen, wird die Karte sogar automatisch beim Start installiert.

## 7. Technische Daten

|                               |                                                                    |
|-------------------------------|--------------------------------------------------------------------|
| <b>Chip-Set:</b>              | FTDI                                                               |
| <b>Datentransfer-Rate:</b>    | 300 Baud bis 921.6 KBaud                                           |
| <b>Anschlüsse:</b>            | 4x 9 Pin seriell RS-232 Stecker                                    |
| <b>Hardwaresystem:</b>        | PCI-Express x1 bis x16                                             |
| <b>Betriebssystem:</b>        | Windows 200x/ XP/ Vista/ 7/ 8.x/ 10/ Server 200xx<br>Linux/ Mac OS |
| <b>Betriebstemperatur:</b>    | 0° bis 55° Celsius                                                 |
| <b>Lagertemperatur:</b>       | -40° bis 75° Celsius                                               |
| <b>Rel. Luftfeuchtigkeit:</b> | 5% bis 95%                                                         |
| <b>Stromversorgung:</b>       | 5V über PCI-Express Slot                                           |
| <b>Abmessung:</b>             | 112,30 x 120,00 mm                                                 |
| <b>Gewicht:</b>               | 200g                                                               |

## 1. Description

The EX-45034IS PCIe I/O card provides four serial RS-232, 422 and 485 high performance UART 16C550 outputs with 15KV ESD Surge Protection and 2.5KV Isolation. It is designed to expand four additional serial ports for PC, small workstation or server via PCIe bus. The card is fully plug-and-play compatible. It supports the ATTA Auto RS-485 transmitter features. Each port can be individually set to RS-232, 422 or 485.

### Features:

- PCI-Express x1 to x16
- 300 Baud up to 921.6 KBAud
- RS-232, RS-422, RS-485 2-wire and RS-485 4-wire
- 15KV ESD Surge Protection & 2.5KV Isolation

## 2. Extent of Delivery

Before you install the EX-45034IS in your PC, you should first check the contents of the delivery:

- EX-45034IS
- Driver CD
- Manual
- Bracket with 2x 9 pin cable

### 3. Layout and Connections

#### 3.1 Layout

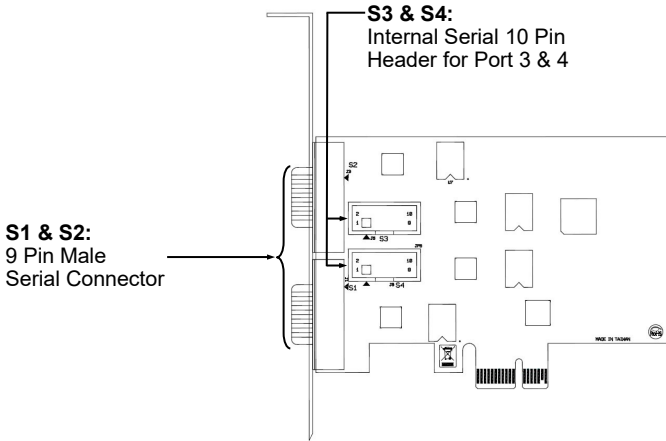

#### 3.2 Connections

RS232 Pin Assignment

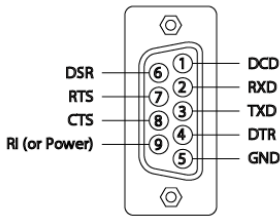

RS422 and RS485-4wire Pin Assignment

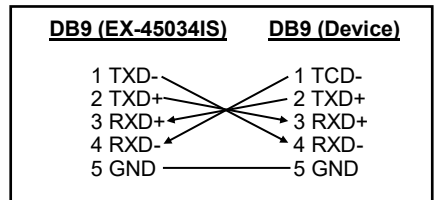
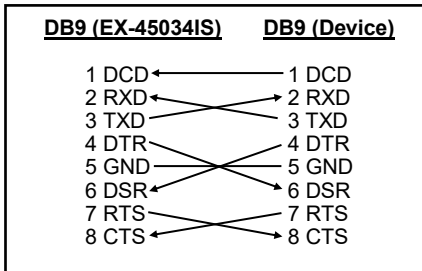
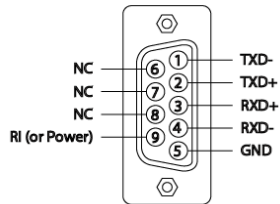

### 3. Layout and Connections

#### 3.2 Connections

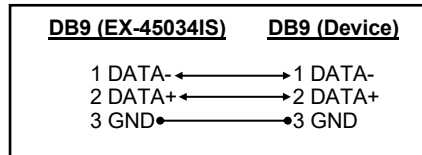
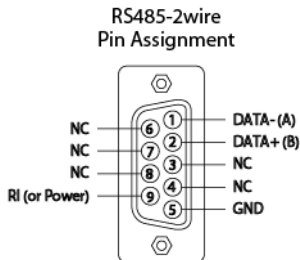

### 4. Switch Settings

There are four 8-pin DIP-switches on the backside of the board at the EX-45034IS. For each port there is a separate DIP-switch. The 8-pin DIP-switches are for the modes (RS-232, RS-422, RS-485 2-wire or RS-485 4-wire) and for the signal termination for RX+, RX-, TX+ and TX- (see picture on page 15). The settings can be set individually for each serial port. The DIP-switch are responsible for the port 1 (S1), the second DIP-switch are responsible for the port 2 (S2) etc.. The following images on page 15, 16 and 17 you can see the setting of the mode switch and terminator switch. Additionally the setting of the mode switch are printed on the back of the board.

## 4. Switch Settings

### Mode & Terminator Switch (S1-S4\_Mode)

| Modes  | RS-232                                                                                                                                                                                                                                                                                                                                                                                                                                          | RS-422 | RS-485 2-wire | RS-485 4-wire |    |    |   |   |  |    |   |   |  |      |   |   |  |    |   |   |  |    |   |   |  |    |   |   |  |    |   |   |  |                                                                                                                                                                                                                                                                                                                                                                                                                                                 |    |   |   |    |    |   |   |  |    |   |   |  |      |   |   |  |    |   |   |  |    |   |   |  |    |   |   |  |    |   |   |  |                                                                                                                                                                                                                                                                                                                                                                                                                                                 |    |   |   |    |    |   |   |  |    |   |   |  |      |   |   |  |    |   |   |  |    |   |   |  |    |   |   |  |    |   |   |  |                                                                                                                                                                                                                                                                                                                                                                                                                                                 |    |   |   |    |    |   |   |  |    |   |   |  |      |   |   |  |    |   |   |  |    |   |   |  |    |   |   |  |    |   |   |  |
|--------|-------------------------------------------------------------------------------------------------------------------------------------------------------------------------------------------------------------------------------------------------------------------------------------------------------------------------------------------------------------------------------------------------------------------------------------------------|--------|---------------|---------------|----|----|---|---|--|----|---|---|--|------|---|---|--|----|---|---|--|----|---|---|--|----|---|---|--|----|---|---|--|-------------------------------------------------------------------------------------------------------------------------------------------------------------------------------------------------------------------------------------------------------------------------------------------------------------------------------------------------------------------------------------------------------------------------------------------------|----|---|---|----|----|---|---|--|----|---|---|--|------|---|---|--|----|---|---|--|----|---|---|--|----|---|---|--|----|---|---|--|-------------------------------------------------------------------------------------------------------------------------------------------------------------------------------------------------------------------------------------------------------------------------------------------------------------------------------------------------------------------------------------------------------------------------------------------------|----|---|---|----|----|---|---|--|----|---|---|--|------|---|---|--|----|---|---|--|----|---|---|--|----|---|---|--|----|---|---|--|-------------------------------------------------------------------------------------------------------------------------------------------------------------------------------------------------------------------------------------------------------------------------------------------------------------------------------------------------------------------------------------------------------------------------------------------------|----|---|---|----|----|---|---|--|----|---|---|--|------|---|---|--|----|---|---|--|----|---|---|--|----|---|---|--|----|---|---|--|
| Port 1 | <table border="1"> <tr><td>M0</td><td>1</td><td>■</td><td>ON</td></tr> <tr><td>M1</td><td>2</td><td>■</td><td></td></tr> <tr><td>M2</td><td>3</td><td>■</td><td></td></tr> <tr><td>TERM</td><td>4</td><td>■</td><td></td></tr> <tr><td>T+</td><td>5</td><td>■</td><td></td></tr> <tr><td>T-</td><td>6</td><td>■</td><td></td></tr> <tr><td>R+</td><td>7</td><td>■</td><td></td></tr> <tr><td>R-</td><td>8</td><td>■</td><td></td></tr> </table> | M0     | 1             | ■             | ON | M1 | 2 | ■ |  | M2 | 3 | ■ |  | TERM | 4 | ■ |  | T+ | 5 | ■ |  | T- | 6 | ■ |  | R+ | 7 | ■ |  | R- | 8 | ■ |  | <table border="1"> <tr><td>M0</td><td>1</td><td>■</td><td>ON</td></tr> <tr><td>M1</td><td>2</td><td>■</td><td></td></tr> <tr><td>M2</td><td>3</td><td>■</td><td></td></tr> <tr><td>TERM</td><td>4</td><td>■</td><td></td></tr> <tr><td>T+</td><td>5</td><td>■</td><td></td></tr> <tr><td>T-</td><td>6</td><td>■</td><td></td></tr> <tr><td>R+</td><td>7</td><td>■</td><td></td></tr> <tr><td>R-</td><td>8</td><td>■</td><td></td></tr> </table> | M0 | 1 | ■ | ON | M1 | 2 | ■ |  | M2 | 3 | ■ |  | TERM | 4 | ■ |  | T+ | 5 | ■ |  | T- | 6 | ■ |  | R+ | 7 | ■ |  | R- | 8 | ■ |  | <table border="1"> <tr><td>M0</td><td>1</td><td>■</td><td>ON</td></tr> <tr><td>M1</td><td>2</td><td>■</td><td></td></tr> <tr><td>M2</td><td>3</td><td>■</td><td></td></tr> <tr><td>TERM</td><td>4</td><td>■</td><td></td></tr> <tr><td>T+</td><td>5</td><td>■</td><td></td></tr> <tr><td>T-</td><td>6</td><td>■</td><td></td></tr> <tr><td>R+</td><td>7</td><td>■</td><td></td></tr> <tr><td>R-</td><td>8</td><td>■</td><td></td></tr> </table> | M0 | 1 | ■ | ON | M1 | 2 | ■ |  | M2 | 3 | ■ |  | TERM | 4 | ■ |  | T+ | 5 | ■ |  | T- | 6 | ■ |  | R+ | 7 | ■ |  | R- | 8 | ■ |  | <table border="1"> <tr><td>M0</td><td>1</td><td>■</td><td>ON</td></tr> <tr><td>M1</td><td>2</td><td>■</td><td></td></tr> <tr><td>M2</td><td>3</td><td>■</td><td></td></tr> <tr><td>TERM</td><td>4</td><td>■</td><td></td></tr> <tr><td>T+</td><td>5</td><td>■</td><td></td></tr> <tr><td>T-</td><td>6</td><td>■</td><td></td></tr> <tr><td>R+</td><td>7</td><td>■</td><td></td></tr> <tr><td>R-</td><td>8</td><td>■</td><td></td></tr> </table> | M0 | 1 | ■ | ON | M1 | 2 | ■ |  | M2 | 3 | ■ |  | TERM | 4 | ■ |  | T+ | 5 | ■ |  | T- | 6 | ■ |  | R+ | 7 | ■ |  | R- | 8 | ■ |  |
| M0     | 1                                                                                                                                                                                                                                                                                                                                                                                                                                               | ■      | ON            |               |    |    |   |   |  |    |   |   |  |      |   |   |  |    |   |   |  |    |   |   |  |    |   |   |  |    |   |   |  |                                                                                                                                                                                                                                                                                                                                                                                                                                                 |    |   |   |    |    |   |   |  |    |   |   |  |      |   |   |  |    |   |   |  |    |   |   |  |    |   |   |  |    |   |   |  |                                                                                                                                                                                                                                                                                                                                                                                                                                                 |    |   |   |    |    |   |   |  |    |   |   |  |      |   |   |  |    |   |   |  |    |   |   |  |    |   |   |  |    |   |   |  |                                                                                                                                                                                                                                                                                                                                                                                                                                                 |    |   |   |    |    |   |   |  |    |   |   |  |      |   |   |  |    |   |   |  |    |   |   |  |    |   |   |  |    |   |   |  |
| M1     | 2                                                                                                                                                                                                                                                                                                                                                                                                                                               | ■      |               |               |    |    |   |   |  |    |   |   |  |      |   |   |  |    |   |   |  |    |   |   |  |    |   |   |  |    |   |   |  |                                                                                                                                                                                                                                                                                                                                                                                                                                                 |    |   |   |    |    |   |   |  |    |   |   |  |      |   |   |  |    |   |   |  |    |   |   |  |    |   |   |  |    |   |   |  |                                                                                                                                                                                                                                                                                                                                                                                                                                                 |    |   |   |    |    |   |   |  |    |   |   |  |      |   |   |  |    |   |   |  |    |   |   |  |    |   |   |  |    |   |   |  |                                                                                                                                                                                                                                                                                                                                                                                                                                                 |    |   |   |    |    |   |   |  |    |   |   |  |      |   |   |  |    |   |   |  |    |   |   |  |    |   |   |  |    |   |   |  |
| M2     | 3                                                                                                                                                                                                                                                                                                                                                                                                                                               | ■      |               |               |    |    |   |   |  |    |   |   |  |      |   |   |  |    |   |   |  |    |   |   |  |    |   |   |  |    |   |   |  |                                                                                                                                                                                                                                                                                                                                                                                                                                                 |    |   |   |    |    |   |   |  |    |   |   |  |      |   |   |  |    |   |   |  |    |   |   |  |    |   |   |  |    |   |   |  |                                                                                                                                                                                                                                                                                                                                                                                                                                                 |    |   |   |    |    |   |   |  |    |   |   |  |      |   |   |  |    |   |   |  |    |   |   |  |    |   |   |  |    |   |   |  |                                                                                                                                                                                                                                                                                                                                                                                                                                                 |    |   |   |    |    |   |   |  |    |   |   |  |      |   |   |  |    |   |   |  |    |   |   |  |    |   |   |  |    |   |   |  |
| TERM   | 4                                                                                                                                                                                                                                                                                                                                                                                                                                               | ■      |               |               |    |    |   |   |  |    |   |   |  |      |   |   |  |    |   |   |  |    |   |   |  |    |   |   |  |    |   |   |  |                                                                                                                                                                                                                                                                                                                                                                                                                                                 |    |   |   |    |    |   |   |  |    |   |   |  |      |   |   |  |    |   |   |  |    |   |   |  |    |   |   |  |    |   |   |  |                                                                                                                                                                                                                                                                                                                                                                                                                                                 |    |   |   |    |    |   |   |  |    |   |   |  |      |   |   |  |    |   |   |  |    |   |   |  |    |   |   |  |    |   |   |  |                                                                                                                                                                                                                                                                                                                                                                                                                                                 |    |   |   |    |    |   |   |  |    |   |   |  |      |   |   |  |    |   |   |  |    |   |   |  |    |   |   |  |    |   |   |  |
| T+     | 5                                                                                                                                                                                                                                                                                                                                                                                                                                               | ■      |               |               |    |    |   |   |  |    |   |   |  |      |   |   |  |    |   |   |  |    |   |   |  |    |   |   |  |    |   |   |  |                                                                                                                                                                                                                                                                                                                                                                                                                                                 |    |   |   |    |    |   |   |  |    |   |   |  |      |   |   |  |    |   |   |  |    |   |   |  |    |   |   |  |    |   |   |  |                                                                                                                                                                                                                                                                                                                                                                                                                                                 |    |   |   |    |    |   |   |  |    |   |   |  |      |   |   |  |    |   |   |  |    |   |   |  |    |   |   |  |    |   |   |  |                                                                                                                                                                                                                                                                                                                                                                                                                                                 |    |   |   |    |    |   |   |  |    |   |   |  |      |   |   |  |    |   |   |  |    |   |   |  |    |   |   |  |    |   |   |  |
| T-     | 6                                                                                                                                                                                                                                                                                                                                                                                                                                               | ■      |               |               |    |    |   |   |  |    |   |   |  |      |   |   |  |    |   |   |  |    |   |   |  |    |   |   |  |    |   |   |  |                                                                                                                                                                                                                                                                                                                                                                                                                                                 |    |   |   |    |    |   |   |  |    |   |   |  |      |   |   |  |    |   |   |  |    |   |   |  |    |   |   |  |    |   |   |  |                                                                                                                                                                                                                                                                                                                                                                                                                                                 |    |   |   |    |    |   |   |  |    |   |   |  |      |   |   |  |    |   |   |  |    |   |   |  |    |   |   |  |    |   |   |  |                                                                                                                                                                                                                                                                                                                                                                                                                                                 |    |   |   |    |    |   |   |  |    |   |   |  |      |   |   |  |    |   |   |  |    |   |   |  |    |   |   |  |    |   |   |  |
| R+     | 7                                                                                                                                                                                                                                                                                                                                                                                                                                               | ■      |               |               |    |    |   |   |  |    |   |   |  |      |   |   |  |    |   |   |  |    |   |   |  |    |   |   |  |    |   |   |  |                                                                                                                                                                                                                                                                                                                                                                                                                                                 |    |   |   |    |    |   |   |  |    |   |   |  |      |   |   |  |    |   |   |  |    |   |   |  |    |   |   |  |    |   |   |  |                                                                                                                                                                                                                                                                                                                                                                                                                                                 |    |   |   |    |    |   |   |  |    |   |   |  |      |   |   |  |    |   |   |  |    |   |   |  |    |   |   |  |    |   |   |  |                                                                                                                                                                                                                                                                                                                                                                                                                                                 |    |   |   |    |    |   |   |  |    |   |   |  |      |   |   |  |    |   |   |  |    |   |   |  |    |   |   |  |    |   |   |  |
| R-     | 8                                                                                                                                                                                                                                                                                                                                                                                                                                               | ■      |               |               |    |    |   |   |  |    |   |   |  |      |   |   |  |    |   |   |  |    |   |   |  |    |   |   |  |    |   |   |  |                                                                                                                                                                                                                                                                                                                                                                                                                                                 |    |   |   |    |    |   |   |  |    |   |   |  |      |   |   |  |    |   |   |  |    |   |   |  |    |   |   |  |    |   |   |  |                                                                                                                                                                                                                                                                                                                                                                                                                                                 |    |   |   |    |    |   |   |  |    |   |   |  |      |   |   |  |    |   |   |  |    |   |   |  |    |   |   |  |    |   |   |  |                                                                                                                                                                                                                                                                                                                                                                                                                                                 |    |   |   |    |    |   |   |  |    |   |   |  |      |   |   |  |    |   |   |  |    |   |   |  |    |   |   |  |    |   |   |  |
| M0     | 1                                                                                                                                                                                                                                                                                                                                                                                                                                               | ■      | ON            |               |    |    |   |   |  |    |   |   |  |      |   |   |  |    |   |   |  |    |   |   |  |    |   |   |  |    |   |   |  |                                                                                                                                                                                                                                                                                                                                                                                                                                                 |    |   |   |    |    |   |   |  |    |   |   |  |      |   |   |  |    |   |   |  |    |   |   |  |    |   |   |  |    |   |   |  |                                                                                                                                                                                                                                                                                                                                                                                                                                                 |    |   |   |    |    |   |   |  |    |   |   |  |      |   |   |  |    |   |   |  |    |   |   |  |    |   |   |  |    |   |   |  |                                                                                                                                                                                                                                                                                                                                                                                                                                                 |    |   |   |    |    |   |   |  |    |   |   |  |      |   |   |  |    |   |   |  |    |   |   |  |    |   |   |  |    |   |   |  |
| M1     | 2                                                                                                                                                                                                                                                                                                                                                                                                                                               | ■      |               |               |    |    |   |   |  |    |   |   |  |      |   |   |  |    |   |   |  |    |   |   |  |    |   |   |  |    |   |   |  |                                                                                                                                                                                                                                                                                                                                                                                                                                                 |    |   |   |    |    |   |   |  |    |   |   |  |      |   |   |  |    |   |   |  |    |   |   |  |    |   |   |  |    |   |   |  |                                                                                                                                                                                                                                                                                                                                                                                                                                                 |    |   |   |    |    |   |   |  |    |   |   |  |      |   |   |  |    |   |   |  |    |   |   |  |    |   |   |  |    |   |   |  |                                                                                                                                                                                                                                                                                                                                                                                                                                                 |    |   |   |    |    |   |   |  |    |   |   |  |      |   |   |  |    |   |   |  |    |   |   |  |    |   |   |  |    |   |   |  |
| M2     | 3                                                                                                                                                                                                                                                                                                                                                                                                                                               | ■      |               |               |    |    |   |   |  |    |   |   |  |      |   |   |  |    |   |   |  |    |   |   |  |    |   |   |  |    |   |   |  |                                                                                                                                                                                                                                                                                                                                                                                                                                                 |    |   |   |    |    |   |   |  |    |   |   |  |      |   |   |  |    |   |   |  |    |   |   |  |    |   |   |  |    |   |   |  |                                                                                                                                                                                                                                                                                                                                                                                                                                                 |    |   |   |    |    |   |   |  |    |   |   |  |      |   |   |  |    |   |   |  |    |   |   |  |    |   |   |  |    |   |   |  |                                                                                                                                                                                                                                                                                                                                                                                                                                                 |    |   |   |    |    |   |   |  |    |   |   |  |      |   |   |  |    |   |   |  |    |   |   |  |    |   |   |  |    |   |   |  |
| TERM   | 4                                                                                                                                                                                                                                                                                                                                                                                                                                               | ■      |               |               |    |    |   |   |  |    |   |   |  |      |   |   |  |    |   |   |  |    |   |   |  |    |   |   |  |    |   |   |  |                                                                                                                                                                                                                                                                                                                                                                                                                                                 |    |   |   |    |    |   |   |  |    |   |   |  |      |   |   |  |    |   |   |  |    |   |   |  |    |   |   |  |    |   |   |  |                                                                                                                                                                                                                                                                                                                                                                                                                                                 |    |   |   |    |    |   |   |  |    |   |   |  |      |   |   |  |    |   |   |  |    |   |   |  |    |   |   |  |    |   |   |  |                                                                                                                                                                                                                                                                                                                                                                                                                                                 |    |   |   |    |    |   |   |  |    |   |   |  |      |   |   |  |    |   |   |  |    |   |   |  |    |   |   |  |    |   |   |  |
| T+     | 5                                                                                                                                                                                                                                                                                                                                                                                                                                               | ■      |               |               |    |    |   |   |  |    |   |   |  |      |   |   |  |    |   |   |  |    |   |   |  |    |   |   |  |    |   |   |  |                                                                                                                                                                                                                                                                                                                                                                                                                                                 |    |   |   |    |    |   |   |  |    |   |   |  |      |   |   |  |    |   |   |  |    |   |   |  |    |   |   |  |    |   |   |  |                                                                                                                                                                                                                                                                                                                                                                                                                                                 |    |   |   |    |    |   |   |  |    |   |   |  |      |   |   |  |    |   |   |  |    |   |   |  |    |   |   |  |    |   |   |  |                                                                                                                                                                                                                                                                                                                                                                                                                                                 |    |   |   |    |    |   |   |  |    |   |   |  |      |   |   |  |    |   |   |  |    |   |   |  |    |   |   |  |    |   |   |  |
| T-     | 6                                                                                                                                                                                                                                                                                                                                                                                                                                               | ■      |               |               |    |    |   |   |  |    |   |   |  |      |   |   |  |    |   |   |  |    |   |   |  |    |   |   |  |    |   |   |  |                                                                                                                                                                                                                                                                                                                                                                                                                                                 |    |   |   |    |    |   |   |  |    |   |   |  |      |   |   |  |    |   |   |  |    |   |   |  |    |   |   |  |    |   |   |  |                                                                                                                                                                                                                                                                                                                                                                                                                                                 |    |   |   |    |    |   |   |  |    |   |   |  |      |   |   |  |    |   |   |  |    |   |   |  |    |   |   |  |    |   |   |  |                                                                                                                                                                                                                                                                                                                                                                                                                                                 |    |   |   |    |    |   |   |  |    |   |   |  |      |   |   |  |    |   |   |  |    |   |   |  |    |   |   |  |    |   |   |  |
| R+     | 7                                                                                                                                                                                                                                                                                                                                                                                                                                               | ■      |               |               |    |    |   |   |  |    |   |   |  |      |   |   |  |    |   |   |  |    |   |   |  |    |   |   |  |    |   |   |  |                                                                                                                                                                                                                                                                                                                                                                                                                                                 |    |   |   |    |    |   |   |  |    |   |   |  |      |   |   |  |    |   |   |  |    |   |   |  |    |   |   |  |    |   |   |  |                                                                                                                                                                                                                                                                                                                                                                                                                                                 |    |   |   |    |    |   |   |  |    |   |   |  |      |   |   |  |    |   |   |  |    |   |   |  |    |   |   |  |    |   |   |  |                                                                                                                                                                                                                                                                                                                                                                                                                                                 |    |   |   |    |    |   |   |  |    |   |   |  |      |   |   |  |    |   |   |  |    |   |   |  |    |   |   |  |    |   |   |  |
| R-     | 8                                                                                                                                                                                                                                                                                                                                                                                                                                               | ■      |               |               |    |    |   |   |  |    |   |   |  |      |   |   |  |    |   |   |  |    |   |   |  |    |   |   |  |    |   |   |  |                                                                                                                                                                                                                                                                                                                                                                                                                                                 |    |   |   |    |    |   |   |  |    |   |   |  |      |   |   |  |    |   |   |  |    |   |   |  |    |   |   |  |    |   |   |  |                                                                                                                                                                                                                                                                                                                                                                                                                                                 |    |   |   |    |    |   |   |  |    |   |   |  |      |   |   |  |    |   |   |  |    |   |   |  |    |   |   |  |    |   |   |  |                                                                                                                                                                                                                                                                                                                                                                                                                                                 |    |   |   |    |    |   |   |  |    |   |   |  |      |   |   |  |    |   |   |  |    |   |   |  |    |   |   |  |    |   |   |  |
| M0     | 1                                                                                                                                                                                                                                                                                                                                                                                                                                               | ■      | ON            |               |    |    |   |   |  |    |   |   |  |      |   |   |  |    |   |   |  |    |   |   |  |    |   |   |  |    |   |   |  |                                                                                                                                                                                                                                                                                                                                                                                                                                                 |    |   |   |    |    |   |   |  |    |   |   |  |      |   |   |  |    |   |   |  |    |   |   |  |    |   |   |  |    |   |   |  |                                                                                                                                                                                                                                                                                                                                                                                                                                                 |    |   |   |    |    |   |   |  |    |   |   |  |      |   |   |  |    |   |   |  |    |   |   |  |    |   |   |  |    |   |   |  |                                                                                                                                                                                                                                                                                                                                                                                                                                                 |    |   |   |    |    |   |   |  |    |   |   |  |      |   |   |  |    |   |   |  |    |   |   |  |    |   |   |  |    |   |   |  |
| M1     | 2                                                                                                                                                                                                                                                                                                                                                                                                                                               | ■      |               |               |    |    |   |   |  |    |   |   |  |      |   |   |  |    |   |   |  |    |   |   |  |    |   |   |  |    |   |   |  |                                                                                                                                                                                                                                                                                                                                                                                                                                                 |    |   |   |    |    |   |   |  |    |   |   |  |      |   |   |  |    |   |   |  |    |   |   |  |    |   |   |  |    |   |   |  |                                                                                                                                                                                                                                                                                                                                                                                                                                                 |    |   |   |    |    |   |   |  |    |   |   |  |      |   |   |  |    |   |   |  |    |   |   |  |    |   |   |  |    |   |   |  |                                                                                                                                                                                                                                                                                                                                                                                                                                                 |    |   |   |    |    |   |   |  |    |   |   |  |      |   |   |  |    |   |   |  |    |   |   |  |    |   |   |  |    |   |   |  |
| M2     | 3                                                                                                                                                                                                                                                                                                                                                                                                                                               | ■      |               |               |    |    |   |   |  |    |   |   |  |      |   |   |  |    |   |   |  |    |   |   |  |    |   |   |  |    |   |   |  |                                                                                                                                                                                                                                                                                                                                                                                                                                                 |    |   |   |    |    |   |   |  |    |   |   |  |      |   |   |  |    |   |   |  |    |   |   |  |    |   |   |  |    |   |   |  |                                                                                                                                                                                                                                                                                                                                                                                                                                                 |    |   |   |    |    |   |   |  |    |   |   |  |      |   |   |  |    |   |   |  |    |   |   |  |    |   |   |  |    |   |   |  |                                                                                                                                                                                                                                                                                                                                                                                                                                                 |    |   |   |    |    |   |   |  |    |   |   |  |      |   |   |  |    |   |   |  |    |   |   |  |    |   |   |  |    |   |   |  |
| TERM   | 4                                                                                                                                                                                                                                                                                                                                                                                                                                               | ■      |               |               |    |    |   |   |  |    |   |   |  |      |   |   |  |    |   |   |  |    |   |   |  |    |   |   |  |    |   |   |  |                                                                                                                                                                                                                                                                                                                                                                                                                                                 |    |   |   |    |    |   |   |  |    |   |   |  |      |   |   |  |    |   |   |  |    |   |   |  |    |   |   |  |    |   |   |  |                                                                                                                                                                                                                                                                                                                                                                                                                                                 |    |   |   |    |    |   |   |  |    |   |   |  |      |   |   |  |    |   |   |  |    |   |   |  |    |   |   |  |    |   |   |  |                                                                                                                                                                                                                                                                                                                                                                                                                                                 |    |   |   |    |    |   |   |  |    |   |   |  |      |   |   |  |    |   |   |  |    |   |   |  |    |   |   |  |    |   |   |  |
| T+     | 5                                                                                                                                                                                                                                                                                                                                                                                                                                               | ■      |               |               |    |    |   |   |  |    |   |   |  |      |   |   |  |    |   |   |  |    |   |   |  |    |   |   |  |    |   |   |  |                                                                                                                                                                                                                                                                                                                                                                                                                                                 |    |   |   |    |    |   |   |  |    |   |   |  |      |   |   |  |    |   |   |  |    |   |   |  |    |   |   |  |    |   |   |  |                                                                                                                                                                                                                                                                                                                                                                                                                                                 |    |   |   |    |    |   |   |  |    |   |   |  |      |   |   |  |    |   |   |  |    |   |   |  |    |   |   |  |    |   |   |  |                                                                                                                                                                                                                                                                                                                                                                                                                                                 |    |   |   |    |    |   |   |  |    |   |   |  |      |   |   |  |    |   |   |  |    |   |   |  |    |   |   |  |    |   |   |  |
| T-     | 6                                                                                                                                                                                                                                                                                                                                                                                                                                               | ■      |               |               |    |    |   |   |  |    |   |   |  |      |   |   |  |    |   |   |  |    |   |   |  |    |   |   |  |    |   |   |  |                                                                                                                                                                                                                                                                                                                                                                                                                                                 |    |   |   |    |    |   |   |  |    |   |   |  |      |   |   |  |    |   |   |  |    |   |   |  |    |   |   |  |    |   |   |  |                                                                                                                                                                                                                                                                                                                                                                                                                                                 |    |   |   |    |    |   |   |  |    |   |   |  |      |   |   |  |    |   |   |  |    |   |   |  |    |   |   |  |    |   |   |  |                                                                                                                                                                                                                                                                                                                                                                                                                                                 |    |   |   |    |    |   |   |  |    |   |   |  |      |   |   |  |    |   |   |  |    |   |   |  |    |   |   |  |    |   |   |  |
| R+     | 7                                                                                                                                                                                                                                                                                                                                                                                                                                               | ■      |               |               |    |    |   |   |  |    |   |   |  |      |   |   |  |    |   |   |  |    |   |   |  |    |   |   |  |    |   |   |  |                                                                                                                                                                                                                                                                                                                                                                                                                                                 |    |   |   |    |    |   |   |  |    |   |   |  |      |   |   |  |    |   |   |  |    |   |   |  |    |   |   |  |    |   |   |  |                                                                                                                                                                                                                                                                                                                                                                                                                                                 |    |   |   |    |    |   |   |  |    |   |   |  |      |   |   |  |    |   |   |  |    |   |   |  |    |   |   |  |    |   |   |  |                                                                                                                                                                                                                                                                                                                                                                                                                                                 |    |   |   |    |    |   |   |  |    |   |   |  |      |   |   |  |    |   |   |  |    |   |   |  |    |   |   |  |    |   |   |  |
| R-     | 8                                                                                                                                                                                                                                                                                                                                                                                                                                               | ■      |               |               |    |    |   |   |  |    |   |   |  |      |   |   |  |    |   |   |  |    |   |   |  |    |   |   |  |    |   |   |  |                                                                                                                                                                                                                                                                                                                                                                                                                                                 |    |   |   |    |    |   |   |  |    |   |   |  |      |   |   |  |    |   |   |  |    |   |   |  |    |   |   |  |    |   |   |  |                                                                                                                                                                                                                                                                                                                                                                                                                                                 |    |   |   |    |    |   |   |  |    |   |   |  |      |   |   |  |    |   |   |  |    |   |   |  |    |   |   |  |    |   |   |  |                                                                                                                                                                                                                                                                                                                                                                                                                                                 |    |   |   |    |    |   |   |  |    |   |   |  |      |   |   |  |    |   |   |  |    |   |   |  |    |   |   |  |    |   |   |  |
| M0     | 1                                                                                                                                                                                                                                                                                                                                                                                                                                               | ■      | ON            |               |    |    |   |   |  |    |   |   |  |      |   |   |  |    |   |   |  |    |   |   |  |    |   |   |  |    |   |   |  |                                                                                                                                                                                                                                                                                                                                                                                                                                                 |    |   |   |    |    |   |   |  |    |   |   |  |      |   |   |  |    |   |   |  |    |   |   |  |    |   |   |  |    |   |   |  |                                                                                                                                                                                                                                                                                                                                                                                                                                                 |    |   |   |    |    |   |   |  |    |   |   |  |      |   |   |  |    |   |   |  |    |   |   |  |    |   |   |  |    |   |   |  |                                                                                                                                                                                                                                                                                                                                                                                                                                                 |    |   |   |    |    |   |   |  |    |   |   |  |      |   |   |  |    |   |   |  |    |   |   |  |    |   |   |  |    |   |   |  |
| M1     | 2                                                                                                                                                                                                                                                                                                                                                                                                                                               | ■      |               |               |    |    |   |   |  |    |   |   |  |      |   |   |  |    |   |   |  |    |   |   |  |    |   |   |  |    |   |   |  |                                                                                                                                                                                                                                                                                                                                                                                                                                                 |    |   |   |    |    |   |   |  |    |   |   |  |      |   |   |  |    |   |   |  |    |   |   |  |    |   |   |  |    |   |   |  |                                                                                                                                                                                                                                                                                                                                                                                                                                                 |    |   |   |    |    |   |   |  |    |   |   |  |      |   |   |  |    |   |   |  |    |   |   |  |    |   |   |  |    |   |   |  |                                                                                                                                                                                                                                                                                                                                                                                                                                                 |    |   |   |    |    |   |   |  |    |   |   |  |      |   |   |  |    |   |   |  |    |   |   |  |    |   |   |  |    |   |   |  |
| M2     | 3                                                                                                                                                                                                                                                                                                                                                                                                                                               | ■      |               |               |    |    |   |   |  |    |   |   |  |      |   |   |  |    |   |   |  |    |   |   |  |    |   |   |  |    |   |   |  |                                                                                                                                                                                                                                                                                                                                                                                                                                                 |    |   |   |    |    |   |   |  |    |   |   |  |      |   |   |  |    |   |   |  |    |   |   |  |    |   |   |  |    |   |   |  |                                                                                                                                                                                                                                                                                                                                                                                                                                                 |    |   |   |    |    |   |   |  |    |   |   |  |      |   |   |  |    |   |   |  |    |   |   |  |    |   |   |  |    |   |   |  |                                                                                                                                                                                                                                                                                                                                                                                                                                                 |    |   |   |    |    |   |   |  |    |   |   |  |      |   |   |  |    |   |   |  |    |   |   |  |    |   |   |  |    |   |   |  |
| TERM   | 4                                                                                                                                                                                                                                                                                                                                                                                                                                               | ■      |               |               |    |    |   |   |  |    |   |   |  |      |   |   |  |    |   |   |  |    |   |   |  |    |   |   |  |    |   |   |  |                                                                                                                                                                                                                                                                                                                                                                                                                                                 |    |   |   |    |    |   |   |  |    |   |   |  |      |   |   |  |    |   |   |  |    |   |   |  |    |   |   |  |    |   |   |  |                                                                                                                                                                                                                                                                                                                                                                                                                                                 |    |   |   |    |    |   |   |  |    |   |   |  |      |   |   |  |    |   |   |  |    |   |   |  |    |   |   |  |    |   |   |  |                                                                                                                                                                                                                                                                                                                                                                                                                                                 |    |   |   |    |    |   |   |  |    |   |   |  |      |   |   |  |    |   |   |  |    |   |   |  |    |   |   |  |    |   |   |  |
| T+     | 5                                                                                                                                                                                                                                                                                                                                                                                                                                               | ■      |               |               |    |    |   |   |  |    |   |   |  |      |   |   |  |    |   |   |  |    |   |   |  |    |   |   |  |    |   |   |  |                                                                                                                                                                                                                                                                                                                                                                                                                                                 |    |   |   |    |    |   |   |  |    |   |   |  |      |   |   |  |    |   |   |  |    |   |   |  |    |   |   |  |    |   |   |  |                                                                                                                                                                                                                                                                                                                                                                                                                                                 |    |   |   |    |    |   |   |  |    |   |   |  |      |   |   |  |    |   |   |  |    |   |   |  |    |   |   |  |    |   |   |  |                                                                                                                                                                                                                                                                                                                                                                                                                                                 |    |   |   |    |    |   |   |  |    |   |   |  |      |   |   |  |    |   |   |  |    |   |   |  |    |   |   |  |    |   |   |  |
| T-     | 6                                                                                                                                                                                                                                                                                                                                                                                                                                               | ■      |               |               |    |    |   |   |  |    |   |   |  |      |   |   |  |    |   |   |  |    |   |   |  |    |   |   |  |    |   |   |  |                                                                                                                                                                                                                                                                                                                                                                                                                                                 |    |   |   |    |    |   |   |  |    |   |   |  |      |   |   |  |    |   |   |  |    |   |   |  |    |   |   |  |    |   |   |  |                                                                                                                                                                                                                                                                                                                                                                                                                                                 |    |   |   |    |    |   |   |  |    |   |   |  |      |   |   |  |    |   |   |  |    |   |   |  |    |   |   |  |    |   |   |  |                                                                                                                                                                                                                                                                                                                                                                                                                                                 |    |   |   |    |    |   |   |  |    |   |   |  |      |   |   |  |    |   |   |  |    |   |   |  |    |   |   |  |    |   |   |  |
| R+     | 7                                                                                                                                                                                                                                                                                                                                                                                                                                               | ■      |               |               |    |    |   |   |  |    |   |   |  |      |   |   |  |    |   |   |  |    |   |   |  |    |   |   |  |    |   |   |  |                                                                                                                                                                                                                                                                                                                                                                                                                                                 |    |   |   |    |    |   |   |  |    |   |   |  |      |   |   |  |    |   |   |  |    |   |   |  |    |   |   |  |    |   |   |  |                                                                                                                                                                                                                                                                                                                                                                                                                                                 |    |   |   |    |    |   |   |  |    |   |   |  |      |   |   |  |    |   |   |  |    |   |   |  |    |   |   |  |    |   |   |  |                                                                                                                                                                                                                                                                                                                                                                                                                                                 |    |   |   |    |    |   |   |  |    |   |   |  |      |   |   |  |    |   |   |  |    |   |   |  |    |   |   |  |    |   |   |  |
| R-     | 8                                                                                                                                                                                                                                                                                                                                                                                                                                               | ■      |               |               |    |    |   |   |  |    |   |   |  |      |   |   |  |    |   |   |  |    |   |   |  |    |   |   |  |    |   |   |  |                                                                                                                                                                                                                                                                                                                                                                                                                                                 |    |   |   |    |    |   |   |  |    |   |   |  |      |   |   |  |    |   |   |  |    |   |   |  |    |   |   |  |    |   |   |  |                                                                                                                                                                                                                                                                                                                                                                                                                                                 |    |   |   |    |    |   |   |  |    |   |   |  |      |   |   |  |    |   |   |  |    |   |   |  |    |   |   |  |    |   |   |  |                                                                                                                                                                                                                                                                                                                                                                                                                                                 |    |   |   |    |    |   |   |  |    |   |   |  |      |   |   |  |    |   |   |  |    |   |   |  |    |   |   |  |    |   |   |  |
| Port 2 | <table border="1"> <tr><td>M0</td><td>1</td><td>■</td><td>ON</td></tr> <tr><td>M1</td><td>2</td><td>■</td><td></td></tr> <tr><td>M2</td><td>3</td><td>■</td><td></td></tr> <tr><td>TERM</td><td>4</td><td>■</td><td></td></tr> <tr><td>T+</td><td>5</td><td>■</td><td></td></tr> <tr><td>T-</td><td>6</td><td>■</td><td></td></tr> <tr><td>R+</td><td>7</td><td>■</td><td></td></tr> <tr><td>R-</td><td>8</td><td>■</td><td></td></tr> </table> | M0     | 1             | ■             | ON | M1 | 2 | ■ |  | M2 | 3 | ■ |  | TERM | 4 | ■ |  | T+ | 5 | ■ |  | T- | 6 | ■ |  | R+ | 7 | ■ |  | R- | 8 | ■ |  | <table border="1"> <tr><td>M0</td><td>1</td><td>■</td><td>ON</td></tr> <tr><td>M1</td><td>2</td><td>■</td><td></td></tr> <tr><td>M2</td><td>3</td><td>■</td><td></td></tr> <tr><td>TERM</td><td>4</td><td>■</td><td></td></tr> <tr><td>T+</td><td>5</td><td>■</td><td></td></tr> <tr><td>T-</td><td>6</td><td>■</td><td></td></tr> <tr><td>R+</td><td>7</td><td>■</td><td></td></tr> <tr><td>R-</td><td>8</td><td>■</td><td></td></tr> </table> | M0 | 1 | ■ | ON | M1 | 2 | ■ |  | M2 | 3 | ■ |  | TERM | 4 | ■ |  | T+ | 5 | ■ |  | T- | 6 | ■ |  | R+ | 7 | ■ |  | R- | 8 | ■ |  | <table border="1"> <tr><td>M0</td><td>1</td><td>■</td><td>ON</td></tr> <tr><td>M1</td><td>2</td><td>■</td><td></td></tr> <tr><td>M2</td><td>3</td><td>■</td><td></td></tr> <tr><td>TERM</td><td>4</td><td>■</td><td></td></tr> <tr><td>T+</td><td>5</td><td>■</td><td></td></tr> <tr><td>T-</td><td>6</td><td>■</td><td></td></tr> <tr><td>R+</td><td>7</td><td>■</td><td></td></tr> <tr><td>R-</td><td>8</td><td>■</td><td></td></tr> </table> | M0 | 1 | ■ | ON | M1 | 2 | ■ |  | M2 | 3 | ■ |  | TERM | 4 | ■ |  | T+ | 5 | ■ |  | T- | 6 | ■ |  | R+ | 7 | ■ |  | R- | 8 | ■ |  | <table border="1"> <tr><td>M0</td><td>1</td><td>■</td><td>ON</td></tr> <tr><td>M1</td><td>2</td><td>■</td><td></td></tr> <tr><td>M2</td><td>3</td><td>■</td><td></td></tr> <tr><td>TERM</td><td>4</td><td>■</td><td></td></tr> <tr><td>T+</td><td>5</td><td>■</td><td></td></tr> <tr><td>T-</td><td>6</td><td>■</td><td></td></tr> <tr><td>R+</td><td>7</td><td>■</td><td></td></tr> <tr><td>R-</td><td>8</td><td>■</td><td></td></tr> </table> | M0 | 1 | ■ | ON | M1 | 2 | ■ |  | M2 | 3 | ■ |  | TERM | 4 | ■ |  | T+ | 5 | ■ |  | T- | 6 | ■ |  | R+ | 7 | ■ |  | R- | 8 | ■ |  |
| M0     | 1                                                                                                                                                                                                                                                                                                                                                                                                                                               | ■      | ON            |               |    |    |   |   |  |    |   |   |  |      |   |   |  |    |   |   |  |    |   |   |  |    |   |   |  |    |   |   |  |                                                                                                                                                                                                                                                                                                                                                                                                                                                 |    |   |   |    |    |   |   |  |    |   |   |  |      |   |   |  |    |   |   |  |    |   |   |  |    |   |   |  |    |   |   |  |                                                                                                                                                                                                                                                                                                                                                                                                                                                 |    |   |   |    |    |   |   |  |    |   |   |  |      |   |   |  |    |   |   |  |    |   |   |  |    |   |   |  |    |   |   |  |                                                                                                                                                                                                                                                                                                                                                                                                                                                 |    |   |   |    |    |   |   |  |    |   |   |  |      |   |   |  |    |   |   |  |    |   |   |  |    |   |   |  |    |   |   |  |
| M1     | 2                                                                                                                                                                                                                                                                                                                                                                                                                                               | ■      |               |               |    |    |   |   |  |    |   |   |  |      |   |   |  |    |   |   |  |    |   |   |  |    |   |   |  |    |   |   |  |                                                                                                                                                                                                                                                                                                                                                                                                                                                 |    |   |   |    |    |   |   |  |    |   |   |  |      |   |   |  |    |   |   |  |    |   |   |  |    |   |   |  |    |   |   |  |                                                                                                                                                                                                                                                                                                                                                                                                                                                 |    |   |   |    |    |   |   |  |    |   |   |  |      |   |   |  |    |   |   |  |    |   |   |  |    |   |   |  |    |   |   |  |                                                                                                                                                                                                                                                                                                                                                                                                                                                 |    |   |   |    |    |   |   |  |    |   |   |  |      |   |   |  |    |   |   |  |    |   |   |  |    |   |   |  |    |   |   |  |
| M2     | 3                                                                                                                                                                                                                                                                                                                                                                                                                                               | ■      |               |               |    |    |   |   |  |    |   |   |  |      |   |   |  |    |   |   |  |    |   |   |  |    |   |   |  |    |   |   |  |                                                                                                                                                                                                                                                                                                                                                                                                                                                 |    |   |   |    |    |   |   |  |    |   |   |  |      |   |   |  |    |   |   |  |    |   |   |  |    |   |   |  |    |   |   |  |                                                                                                                                                                                                                                                                                                                                                                                                                                                 |    |   |   |    |    |   |   |  |    |   |   |  |      |   |   |  |    |   |   |  |    |   |   |  |    |   |   |  |    |   |   |  |                                                                                                                                                                                                                                                                                                                                                                                                                                                 |    |   |   |    |    |   |   |  |    |   |   |  |      |   |   |  |    |   |   |  |    |   |   |  |    |   |   |  |    |   |   |  |
| TERM   | 4                                                                                                                                                                                                                                                                                                                                                                                                                                               | ■      |               |               |    |    |   |   |  |    |   |   |  |      |   |   |  |    |   |   |  |    |   |   |  |    |   |   |  |    |   |   |  |                                                                                                                                                                                                                                                                                                                                                                                                                                                 |    |   |   |    |    |   |   |  |    |   |   |  |      |   |   |  |    |   |   |  |    |   |   |  |    |   |   |  |    |   |   |  |                                                                                                                                                                                                                                                                                                                                                                                                                                                 |    |   |   |    |    |   |   |  |    |   |   |  |      |   |   |  |    |   |   |  |    |   |   |  |    |   |   |  |    |   |   |  |                                                                                                                                                                                                                                                                                                                                                                                                                                                 |    |   |   |    |    |   |   |  |    |   |   |  |      |   |   |  |    |   |   |  |    |   |   |  |    |   |   |  |    |   |   |  |
| T+     | 5                                                                                                                                                                                                                                                                                                                                                                                                                                               | ■      |               |               |    |    |   |   |  |    |   |   |  |      |   |   |  |    |   |   |  |    |   |   |  |    |   |   |  |    |   |   |  |                                                                                                                                                                                                                                                                                                                                                                                                                                                 |    |   |   |    |    |   |   |  |    |   |   |  |      |   |   |  |    |   |   |  |    |   |   |  |    |   |   |  |    |   |   |  |                                                                                                                                                                                                                                                                                                                                                                                                                                                 |    |   |   |    |    |   |   |  |    |   |   |  |      |   |   |  |    |   |   |  |    |   |   |  |    |   |   |  |    |   |   |  |                                                                                                                                                                                                                                                                                                                                                                                                                                                 |    |   |   |    |    |   |   |  |    |   |   |  |      |   |   |  |    |   |   |  |    |   |   |  |    |   |   |  |    |   |   |  |
| T-     | 6                                                                                                                                                                                                                                                                                                                                                                                                                                               | ■      |               |               |    |    |   |   |  |    |   |   |  |      |   |   |  |    |   |   |  |    |   |   |  |    |   |   |  |    |   |   |  |                                                                                                                                                                                                                                                                                                                                                                                                                                                 |    |   |   |    |    |   |   |  |    |   |   |  |      |   |   |  |    |   |   |  |    |   |   |  |    |   |   |  |    |   |   |  |                                                                                                                                                                                                                                                                                                                                                                                                                                                 |    |   |   |    |    |   |   |  |    |   |   |  |      |   |   |  |    |   |   |  |    |   |   |  |    |   |   |  |    |   |   |  |                                                                                                                                                                                                                                                                                                                                                                                                                                                 |    |   |   |    |    |   |   |  |    |   |   |  |      |   |   |  |    |   |   |  |    |   |   |  |    |   |   |  |    |   |   |  |
| R+     | 7                                                                                                                                                                                                                                                                                                                                                                                                                                               | ■      |               |               |    |    |   |   |  |    |   |   |  |      |   |   |  |    |   |   |  |    |   |   |  |    |   |   |  |    |   |   |  |                                                                                                                                                                                                                                                                                                                                                                                                                                                 |    |   |   |    |    |   |   |  |    |   |   |  |      |   |   |  |    |   |   |  |    |   |   |  |    |   |   |  |    |   |   |  |                                                                                                                                                                                                                                                                                                                                                                                                                                                 |    |   |   |    |    |   |   |  |    |   |   |  |      |   |   |  |    |   |   |  |    |   |   |  |    |   |   |  |    |   |   |  |                                                                                                                                                                                                                                                                                                                                                                                                                                                 |    |   |   |    |    |   |   |  |    |   |   |  |      |   |   |  |    |   |   |  |    |   |   |  |    |   |   |  |    |   |   |  |
| R-     | 8                                                                                                                                                                                                                                                                                                                                                                                                                                               | ■      |               |               |    |    |   |   |  |    |   |   |  |      |   |   |  |    |   |   |  |    |   |   |  |    |   |   |  |    |   |   |  |                                                                                                                                                                                                                                                                                                                                                                                                                                                 |    |   |   |    |    |   |   |  |    |   |   |  |      |   |   |  |    |   |   |  |    |   |   |  |    |   |   |  |    |   |   |  |                                                                                                                                                                                                                                                                                                                                                                                                                                                 |    |   |   |    |    |   |   |  |    |   |   |  |      |   |   |  |    |   |   |  |    |   |   |  |    |   |   |  |    |   |   |  |                                                                                                                                                                                                                                                                                                                                                                                                                                                 |    |   |   |    |    |   |   |  |    |   |   |  |      |   |   |  |    |   |   |  |    |   |   |  |    |   |   |  |    |   |   |  |
| M0     | 1                                                                                                                                                                                                                                                                                                                                                                                                                                               | ■      | ON            |               |    |    |   |   |  |    |   |   |  |      |   |   |  |    |   |   |  |    |   |   |  |    |   |   |  |    |   |   |  |                                                                                                                                                                                                                                                                                                                                                                                                                                                 |    |   |   |    |    |   |   |  |    |   |   |  |      |   |   |  |    |   |   |  |    |   |   |  |    |   |   |  |    |   |   |  |                                                                                                                                                                                                                                                                                                                                                                                                                                                 |    |   |   |    |    |   |   |  |    |   |   |  |      |   |   |  |    |   |   |  |    |   |   |  |    |   |   |  |    |   |   |  |                                                                                                                                                                                                                                                                                                                                                                                                                                                 |    |   |   |    |    |   |   |  |    |   |   |  |      |   |   |  |    |   |   |  |    |   |   |  |    |   |   |  |    |   |   |  |
| M1     | 2                                                                                                                                                                                                                                                                                                                                                                                                                                               | ■      |               |               |    |    |   |   |  |    |   |   |  |      |   |   |  |    |   |   |  |    |   |   |  |    |   |   |  |    |   |   |  |                                                                                                                                                                                                                                                                                                                                                                                                                                                 |    |   |   |    |    |   |   |  |    |   |   |  |      |   |   |  |    |   |   |  |    |   |   |  |    |   |   |  |    |   |   |  |                                                                                                                                                                                                                                                                                                                                                                                                                                                 |    |   |   |    |    |   |   |  |    |   |   |  |      |   |   |  |    |   |   |  |    |   |   |  |    |   |   |  |    |   |   |  |                                                                                                                                                                                                                                                                                                                                                                                                                                                 |    |   |   |    |    |   |   |  |    |   |   |  |      |   |   |  |    |   |   |  |    |   |   |  |    |   |   |  |    |   |   |  |
| M2     | 3                                                                                                                                                                                                                                                                                                                                                                                                                                               | ■      |               |               |    |    |   |   |  |    |   |   |  |      |   |   |  |    |   |   |  |    |   |   |  |    |   |   |  |    |   |   |  |                                                                                                                                                                                                                                                                                                                                                                                                                                                 |    |   |   |    |    |   |   |  |    |   |   |  |      |   |   |  |    |   |   |  |    |   |   |  |    |   |   |  |    |   |   |  |                                                                                                                                                                                                                                                                                                                                                                                                                                                 |    |   |   |    |    |   |   |  |    |   |   |  |      |   |   |  |    |   |   |  |    |   |   |  |    |   |   |  |    |   |   |  |                                                                                                                                                                                                                                                                                                                                                                                                                                                 |    |   |   |    |    |   |   |  |    |   |   |  |      |   |   |  |    |   |   |  |    |   |   |  |    |   |   |  |    |   |   |  |
| TERM   | 4                                                                                                                                                                                                                                                                                                                                                                                                                                               | ■      |               |               |    |    |   |   |  |    |   |   |  |      |   |   |  |    |   |   |  |    |   |   |  |    |   |   |  |    |   |   |  |                                                                                                                                                                                                                                                                                                                                                                                                                                                 |    |   |   |    |    |   |   |  |    |   |   |  |      |   |   |  |    |   |   |  |    |   |   |  |    |   |   |  |    |   |   |  |                                                                                                                                                                                                                                                                                                                                                                                                                                                 |    |   |   |    |    |   |   |  |    |   |   |  |      |   |   |  |    |   |   |  |    |   |   |  |    |   |   |  |    |   |   |  |                                                                                                                                                                                                                                                                                                                                                                                                                                                 |    |   |   |    |    |   |   |  |    |   |   |  |      |   |   |  |    |   |   |  |    |   |   |  |    |   |   |  |    |   |   |  |
| T+     | 5                                                                                                                                                                                                                                                                                                                                                                                                                                               | ■      |               |               |    |    |   |   |  |    |   |   |  |      |   |   |  |    |   |   |  |    |   |   |  |    |   |   |  |    |   |   |  |                                                                                                                                                                                                                                                                                                                                                                                                                                                 |    |   |   |    |    |   |   |  |    |   |   |  |      |   |   |  |    |   |   |  |    |   |   |  |    |   |   |  |    |   |   |  |                                                                                                                                                                                                                                                                                                                                                                                                                                                 |    |   |   |    |    |   |   |  |    |   |   |  |      |   |   |  |    |   |   |  |    |   |   |  |    |   |   |  |    |   |   |  |                                                                                                                                                                                                                                                                                                                                                                                                                                                 |    |   |   |    |    |   |   |  |    |   |   |  |      |   |   |  |    |   |   |  |    |   |   |  |    |   |   |  |    |   |   |  |
| T-     | 6                                                                                                                                                                                                                                                                                                                                                                                                                                               | ■      |               |               |    |    |   |   |  |    |   |   |  |      |   |   |  |    |   |   |  |    |   |   |  |    |   |   |  |    |   |   |  |                                                                                                                                                                                                                                                                                                                                                                                                                                                 |    |   |   |    |    |   |   |  |    |   |   |  |      |   |   |  |    |   |   |  |    |   |   |  |    |   |   |  |    |   |   |  |                                                                                                                                                                                                                                                                                                                                                                                                                                                 |    |   |   |    |    |   |   |  |    |   |   |  |      |   |   |  |    |   |   |  |    |   |   |  |    |   |   |  |    |   |   |  |                                                                                                                                                                                                                                                                                                                                                                                                                                                 |    |   |   |    |    |   |   |  |    |   |   |  |      |   |   |  |    |   |   |  |    |   |   |  |    |   |   |  |    |   |   |  |
| R+     | 7                                                                                                                                                                                                                                                                                                                                                                                                                                               | ■      |               |               |    |    |   |   |  |    |   |   |  |      |   |   |  |    |   |   |  |    |   |   |  |    |   |   |  |    |   |   |  |                                                                                                                                                                                                                                                                                                                                                                                                                                                 |    |   |   |    |    |   |   |  |    |   |   |  |      |   |   |  |    |   |   |  |    |   |   |  |    |   |   |  |    |   |   |  |                                                                                                                                                                                                                                                                                                                                                                                                                                                 |    |   |   |    |    |   |   |  |    |   |   |  |      |   |   |  |    |   |   |  |    |   |   |  |    |   |   |  |    |   |   |  |                                                                                                                                                                                                                                                                                                                                                                                                                                                 |    |   |   |    |    |   |   |  |    |   |   |  |      |   |   |  |    |   |   |  |    |   |   |  |    |   |   |  |    |   |   |  |
| R-     | 8                                                                                                                                                                                                                                                                                                                                                                                                                                               | ■      |               |               |    |    |   |   |  |    |   |   |  |      |   |   |  |    |   |   |  |    |   |   |  |    |   |   |  |    |   |   |  |                                                                                                                                                                                                                                                                                                                                                                                                                                                 |    |   |   |    |    |   |   |  |    |   |   |  |      |   |   |  |    |   |   |  |    |   |   |  |    |   |   |  |    |   |   |  |                                                                                                                                                                                                                                                                                                                                                                                                                                                 |    |   |   |    |    |   |   |  |    |   |   |  |      |   |   |  |    |   |   |  |    |   |   |  |    |   |   |  |    |   |   |  |                                                                                                                                                                                                                                                                                                                                                                                                                                                 |    |   |   |    |    |   |   |  |    |   |   |  |      |   |   |  |    |   |   |  |    |   |   |  |    |   |   |  |    |   |   |  |
| M0     | 1                                                                                                                                                                                                                                                                                                                                                                                                                                               | ■      | ON            |               |    |    |   |   |  |    |   |   |  |      |   |   |  |    |   |   |  |    |   |   |  |    |   |   |  |    |   |   |  |                                                                                                                                                                                                                                                                                                                                                                                                                                                 |    |   |   |    |    |   |   |  |    |   |   |  |      |   |   |  |    |   |   |  |    |   |   |  |    |   |   |  |    |   |   |  |                                                                                                                                                                                                                                                                                                                                                                                                                                                 |    |   |   |    |    |   |   |  |    |   |   |  |      |   |   |  |    |   |   |  |    |   |   |  |    |   |   |  |    |   |   |  |                                                                                                                                                                                                                                                                                                                                                                                                                                                 |    |   |   |    |    |   |   |  |    |   |   |  |      |   |   |  |    |   |   |  |    |   |   |  |    |   |   |  |    |   |   |  |
| M1     | 2                                                                                                                                                                                                                                                                                                                                                                                                                                               | ■      |               |               |    |    |   |   |  |    |   |   |  |      |   |   |  |    |   |   |  |    |   |   |  |    |   |   |  |    |   |   |  |                                                                                                                                                                                                                                                                                                                                                                                                                                                 |    |   |   |    |    |   |   |  |    |   |   |  |      |   |   |  |    |   |   |  |    |   |   |  |    |   |   |  |    |   |   |  |                                                                                                                                                                                                                                                                                                                                                                                                                                                 |    |   |   |    |    |   |   |  |    |   |   |  |      |   |   |  |    |   |   |  |    |   |   |  |    |   |   |  |    |   |   |  |                                                                                                                                                                                                                                                                                                                                                                                                                                                 |    |   |   |    |    |   |   |  |    |   |   |  |      |   |   |  |    |   |   |  |    |   |   |  |    |   |   |  |    |   |   |  |
| M2     | 3                                                                                                                                                                                                                                                                                                                                                                                                                                               | ■      |               |               |    |    |   |   |  |    |   |   |  |      |   |   |  |    |   |   |  |    |   |   |  |    |   |   |  |    |   |   |  |                                                                                                                                                                                                                                                                                                                                                                                                                                                 |    |   |   |    |    |   |   |  |    |   |   |  |      |   |   |  |    |   |   |  |    |   |   |  |    |   |   |  |    |   |   |  |                                                                                                                                                                                                                                                                                                                                                                                                                                                 |    |   |   |    |    |   |   |  |    |   |   |  |      |   |   |  |    |   |   |  |    |   |   |  |    |   |   |  |    |   |   |  |                                                                                                                                                                                                                                                                                                                                                                                                                                                 |    |   |   |    |    |   |   |  |    |   |   |  |      |   |   |  |    |   |   |  |    |   |   |  |    |   |   |  |    |   |   |  |
| TERM   | 4                                                                                                                                                                                                                                                                                                                                                                                                                                               | ■      |               |               |    |    |   |   |  |    |   |   |  |      |   |   |  |    |   |   |  |    |   |   |  |    |   |   |  |    |   |   |  |                                                                                                                                                                                                                                                                                                                                                                                                                                                 |    |   |   |    |    |   |   |  |    |   |   |  |      |   |   |  |    |   |   |  |    |   |   |  |    |   |   |  |    |   |   |  |                                                                                                                                                                                                                                                                                                                                                                                                                                                 |    |   |   |    |    |   |   |  |    |   |   |  |      |   |   |  |    |   |   |  |    |   |   |  |    |   |   |  |    |   |   |  |                                                                                                                                                                                                                                                                                                                                                                                                                                                 |    |   |   |    |    |   |   |  |    |   |   |  |      |   |   |  |    |   |   |  |    |   |   |  |    |   |   |  |    |   |   |  |
| T+     | 5                                                                                                                                                                                                                                                                                                                                                                                                                                               | ■      |               |               |    |    |   |   |  |    |   |   |  |      |   |   |  |    |   |   |  |    |   |   |  |    |   |   |  |    |   |   |  |                                                                                                                                                                                                                                                                                                                                                                                                                                                 |    |   |   |    |    |   |   |  |    |   |   |  |      |   |   |  |    |   |   |  |    |   |   |  |    |   |   |  |    |   |   |  |                                                                                                                                                                                                                                                                                                                                                                                                                                                 |    |   |   |    |    |   |   |  |    |   |   |  |      |   |   |  |    |   |   |  |    |   |   |  |    |   |   |  |    |   |   |  |                                                                                                                                                                                                                                                                                                                                                                                                                                                 |    |   |   |    |    |   |   |  |    |   |   |  |      |   |   |  |    |   |   |  |    |   |   |  |    |   |   |  |    |   |   |  |
| T-     | 6                                                                                                                                                                                                                                                                                                                                                                                                                                               | ■      |               |               |    |    |   |   |  |    |   |   |  |      |   |   |  |    |   |   |  |    |   |   |  |    |   |   |  |    |   |   |  |                                                                                                                                                                                                                                                                                                                                                                                                                                                 |    |   |   |    |    |   |   |  |    |   |   |  |      |   |   |  |    |   |   |  |    |   |   |  |    |   |   |  |    |   |   |  |                                                                                                                                                                                                                                                                                                                                                                                                                                                 |    |   |   |    |    |   |   |  |    |   |   |  |      |   |   |  |    |   |   |  |    |   |   |  |    |   |   |  |    |   |   |  |                                                                                                                                                                                                                                                                                                                                                                                                                                                 |    |   |   |    |    |   |   |  |    |   |   |  |      |   |   |  |    |   |   |  |    |   |   |  |    |   |   |  |    |   |   |  |
| R+     | 7                                                                                                                                                                                                                                                                                                                                                                                                                                               | ■      |               |               |    |    |   |   |  |    |   |   |  |      |   |   |  |    |   |   |  |    |   |   |  |    |   |   |  |    |   |   |  |                                                                                                                                                                                                                                                                                                                                                                                                                                                 |    |   |   |    |    |   |   |  |    |   |   |  |      |   |   |  |    |   |   |  |    |   |   |  |    |   |   |  |    |   |   |  |                                                                                                                                                                                                                                                                                                                                                                                                                                                 |    |   |   |    |    |   |   |  |    |   |   |  |      |   |   |  |    |   |   |  |    |   |   |  |    |   |   |  |    |   |   |  |                                                                                                                                                                                                                                                                                                                                                                                                                                                 |    |   |   |    |    |   |   |  |    |   |   |  |      |   |   |  |    |   |   |  |    |   |   |  |    |   |   |  |    |   |   |  |
| R-     | 8                                                                                                                                                                                                                                                                                                                                                                                                                                               | ■      |               |               |    |    |   |   |  |    |   |   |  |      |   |   |  |    |   |   |  |    |   |   |  |    |   |   |  |    |   |   |  |                                                                                                                                                                                                                                                                                                                                                                                                                                                 |    |   |   |    |    |   |   |  |    |   |   |  |      |   |   |  |    |   |   |  |    |   |   |  |    |   |   |  |    |   |   |  |                                                                                                                                                                                                                                                                                                                                                                                                                                                 |    |   |   |    |    |   |   |  |    |   |   |  |      |   |   |  |    |   |   |  |    |   |   |  |    |   |   |  |    |   |   |  |                                                                                                                                                                                                                                                                                                                                                                                                                                                 |    |   |   |    |    |   |   |  |    |   |   |  |      |   |   |  |    |   |   |  |    |   |   |  |    |   |   |  |    |   |   |  |
| M0     | 1                                                                                                                                                                                                                                                                                                                                                                                                                                               | ■      | ON            |               |    |    |   |   |  |    |   |   |  |      |   |   |  |    |   |   |  |    |   |   |  |    |   |   |  |    |   |   |  |                                                                                                                                                                                                                                                                                                                                                                                                                                                 |    |   |   |    |    |   |   |  |    |   |   |  |      |   |   |  |    |   |   |  |    |   |   |  |    |   |   |  |    |   |   |  |                                                                                                                                                                                                                                                                                                                                                                                                                                                 |    |   |   |    |    |   |   |  |    |   |   |  |      |   |   |  |    |   |   |  |    |   |   |  |    |   |   |  |    |   |   |  |                                                                                                                                                                                                                                                                                                                                                                                                                                                 |    |   |   |    |    |   |   |  |    |   |   |  |      |   |   |  |    |   |   |  |    |   |   |  |    |   |   |  |    |   |   |  |
| M1     | 2                                                                                                                                                                                                                                                                                                                                                                                                                                               | ■      |               |               |    |    |   |   |  |    |   |   |  |      |   |   |  |    |   |   |  |    |   |   |  |    |   |   |  |    |   |   |  |                                                                                                                                                                                                                                                                                                                                                                                                                                                 |    |   |   |    |    |   |   |  |    |   |   |  |      |   |   |  |    |   |   |  |    |   |   |  |    |   |   |  |    |   |   |  |                                                                                                                                                                                                                                                                                                                                                                                                                                                 |    |   |   |    |    |   |   |  |    |   |   |  |      |   |   |  |    |   |   |  |    |   |   |  |    |   |   |  |    |   |   |  |                                                                                                                                                                                                                                                                                                                                                                                                                                                 |    |   |   |    |    |   |   |  |    |   |   |  |      |   |   |  |    |   |   |  |    |   |   |  |    |   |   |  |    |   |   |  |
| M2     | 3                                                                                                                                                                                                                                                                                                                                                                                                                                               | ■      |               |               |    |    |   |   |  |    |   |   |  |      |   |   |  |    |   |   |  |    |   |   |  |    |   |   |  |    |   |   |  |                                                                                                                                                                                                                                                                                                                                                                                                                                                 |    |   |   |    |    |   |   |  |    |   |   |  |      |   |   |  |    |   |   |  |    |   |   |  |    |   |   |  |    |   |   |  |                                                                                                                                                                                                                                                                                                                                                                                                                                                 |    |   |   |    |    |   |   |  |    |   |   |  |      |   |   |  |    |   |   |  |    |   |   |  |    |   |   |  |    |   |   |  |                                                                                                                                                                                                                                                                                                                                                                                                                                                 |    |   |   |    |    |   |   |  |    |   |   |  |      |   |   |  |    |   |   |  |    |   |   |  |    |   |   |  |    |   |   |  |
| TERM   | 4                                                                                                                                                                                                                                                                                                                                                                                                                                               | ■      |               |               |    |    |   |   |  |    |   |   |  |      |   |   |  |    |   |   |  |    |   |   |  |    |   |   |  |    |   |   |  |                                                                                                                                                                                                                                                                                                                                                                                                                                                 |    |   |   |    |    |   |   |  |    |   |   |  |      |   |   |  |    |   |   |  |    |   |   |  |    |   |   |  |    |   |   |  |                                                                                                                                                                                                                                                                                                                                                                                                                                                 |    |   |   |    |    |   |   |  |    |   |   |  |      |   |   |  |    |   |   |  |    |   |   |  |    |   |   |  |    |   |   |  |                                                                                                                                                                                                                                                                                                                                                                                                                                                 |    |   |   |    |    |   |   |  |    |   |   |  |      |   |   |  |    |   |   |  |    |   |   |  |    |   |   |  |    |   |   |  |
| T+     | 5                                                                                                                                                                                                                                                                                                                                                                                                                                               | ■      |               |               |    |    |   |   |  |    |   |   |  |      |   |   |  |    |   |   |  |    |   |   |  |    |   |   |  |    |   |   |  |                                                                                                                                                                                                                                                                                                                                                                                                                                                 |    |   |   |    |    |   |   |  |    |   |   |  |      |   |   |  |    |   |   |  |    |   |   |  |    |   |   |  |    |   |   |  |                                                                                                                                                                                                                                                                                                                                                                                                                                                 |    |   |   |    |    |   |   |  |    |   |   |  |      |   |   |  |    |   |   |  |    |   |   |  |    |   |   |  |    |   |   |  |                                                                                                                                                                                                                                                                                                                                                                                                                                                 |    |   |   |    |    |   |   |  |    |   |   |  |      |   |   |  |    |   |   |  |    |   |   |  |    |   |   |  |    |   |   |  |
| T-     | 6                                                                                                                                                                                                                                                                                                                                                                                                                                               | ■      |               |               |    |    |   |   |  |    |   |   |  |      |   |   |  |    |   |   |  |    |   |   |  |    |   |   |  |    |   |   |  |                                                                                                                                                                                                                                                                                                                                                                                                                                                 |    |   |   |    |    |   |   |  |    |   |   |  |      |   |   |  |    |   |   |  |    |   |   |  |    |   |   |  |    |   |   |  |                                                                                                                                                                                                                                                                                                                                                                                                                                                 |    |   |   |    |    |   |   |  |    |   |   |  |      |   |   |  |    |   |   |  |    |   |   |  |    |   |   |  |    |   |   |  |                                                                                                                                                                                                                                                                                                                                                                                                                                                 |    |   |   |    |    |   |   |  |    |   |   |  |      |   |   |  |    |   |   |  |    |   |   |  |    |   |   |  |    |   |   |  |
| R+     | 7                                                                                                                                                                                                                                                                                                                                                                                                                                               | ■      |               |               |    |    |   |   |  |    |   |   |  |      |   |   |  |    |   |   |  |    |   |   |  |    |   |   |  |    |   |   |  |                                                                                                                                                                                                                                                                                                                                                                                                                                                 |    |   |   |    |    |   |   |  |    |   |   |  |      |   |   |  |    |   |   |  |    |   |   |  |    |   |   |  |    |   |   |  |                                                                                                                                                                                                                                                                                                                                                                                                                                                 |    |   |   |    |    |   |   |  |    |   |   |  |      |   |   |  |    |   |   |  |    |   |   |  |    |   |   |  |    |   |   |  |                                                                                                                                                                                                                                                                                                                                                                                                                                                 |    |   |   |    |    |   |   |  |    |   |   |  |      |   |   |  |    |   |   |  |    |   |   |  |    |   |   |  |    |   |   |  |
| R-     | 8                                                                                                                                                                                                                                                                                                                                                                                                                                               | ■      |               |               |    |    |   |   |  |    |   |   |  |      |   |   |  |    |   |   |  |    |   |   |  |    |   |   |  |    |   |   |  |                                                                                                                                                                                                                                                                                                                                                                                                                                                 |    |   |   |    |    |   |   |  |    |   |   |  |      |   |   |  |    |   |   |  |    |   |   |  |    |   |   |  |    |   |   |  |                                                                                                                                                                                                                                                                                                                                                                                                                                                 |    |   |   |    |    |   |   |  |    |   |   |  |      |   |   |  |    |   |   |  |    |   |   |  |    |   |   |  |    |   |   |  |                                                                                                                                                                                                                                                                                                                                                                                                                                                 |    |   |   |    |    |   |   |  |    |   |   |  |      |   |   |  |    |   |   |  |    |   |   |  |    |   |   |  |    |   |   |  |
| Port 3 | <table border="1"> <tr><td>M0</td><td>1</td><td>■</td><td>ON</td></tr> <tr><td>M1</td><td>2</td><td>■</td><td></td></tr> <tr><td>M2</td><td>3</td><td>■</td><td></td></tr> <tr><td>TERM</td><td>4</td><td>■</td><td></td></tr> <tr><td>T+</td><td>5</td><td>■</td><td></td></tr> <tr><td>T-</td><td>6</td><td>■</td><td></td></tr> <tr><td>R+</td><td>7</td><td>■</td><td></td></tr> <tr><td>R-</td><td>8</td><td>■</td><td></td></tr> </table> | M0     | 1             | ■             | ON | M1 | 2 | ■ |  | M2 | 3 | ■ |  | TERM | 4 | ■ |  | T+ | 5 | ■ |  | T- | 6 | ■ |  | R+ | 7 | ■ |  | R- | 8 | ■ |  | <table border="1"> <tr><td>M0</td><td>1</td><td>■</td><td>ON</td></tr> <tr><td>M1</td><td>2</td><td>■</td><td></td></tr> <tr><td>M2</td><td>3</td><td>■</td><td></td></tr> <tr><td>TERM</td><td>4</td><td>■</td><td></td></tr> <tr><td>T+</td><td>5</td><td>■</td><td></td></tr> <tr><td>T-</td><td>6</td><td>■</td><td></td></tr> <tr><td>R+</td><td>7</td><td>■</td><td></td></tr> <tr><td>R-</td><td>8</td><td>■</td><td></td></tr> </table> | M0 | 1 | ■ | ON | M1 | 2 | ■ |  | M2 | 3 | ■ |  | TERM | 4 | ■ |  | T+ | 5 | ■ |  | T- | 6 | ■ |  | R+ | 7 | ■ |  | R- | 8 | ■ |  | <table border="1"> <tr><td>M0</td><td>1</td><td>■</td><td>ON</td></tr> <tr><td>M1</td><td>2</td><td>■</td><td></td></tr> <tr><td>M2</td><td>3</td><td>■</td><td></td></tr> <tr><td>TERM</td><td>4</td><td>■</td><td></td></tr> <tr><td>T+</td><td>5</td><td>■</td><td></td></tr> <tr><td>T-</td><td>6</td><td>■</td><td></td></tr> <tr><td>R+</td><td>7</td><td>■</td><td></td></tr> <tr><td>R-</td><td>8</td><td>■</td><td></td></tr> </table> | M0 | 1 | ■ | ON | M1 | 2 | ■ |  | M2 | 3 | ■ |  | TERM | 4 | ■ |  | T+ | 5 | ■ |  | T- | 6 | ■ |  | R+ | 7 | ■ |  | R- | 8 | ■ |  | <table border="1"> <tr><td>M0</td><td>1</td><td>■</td><td>ON</td></tr> <tr><td>M1</td><td>2</td><td>■</td><td></td></tr> <tr><td>M2</td><td>3</td><td>■</td><td></td></tr> <tr><td>TERM</td><td>4</td><td>■</td><td></td></tr> <tr><td>T+</td><td>5</td><td>■</td><td></td></tr> <tr><td>T-</td><td>6</td><td>■</td><td></td></tr> <tr><td>R+</td><td>7</td><td>■</td><td></td></tr> <tr><td>R-</td><td>8</td><td>■</td><td></td></tr> </table> | M0 | 1 | ■ | ON | M1 | 2 | ■ |  | M2 | 3 | ■ |  | TERM | 4 | ■ |  | T+ | 5 | ■ |  | T- | 6 | ■ |  | R+ | 7 | ■ |  | R- | 8 | ■ |  |
| M0     | 1                                                                                                                                                                                                                                                                                                                                                                                                                                               | ■      | ON            |               |    |    |   |   |  |    |   |   |  |      |   |   |  |    |   |   |  |    |   |   |  |    |   |   |  |    |   |   |  |                                                                                                                                                                                                                                                                                                                                                                                                                                                 |    |   |   |    |    |   |   |  |    |   |   |  |      |   |   |  |    |   |   |  |    |   |   |  |    |   |   |  |    |   |   |  |                                                                                                                                                                                                                                                                                                                                                                                                                                                 |    |   |   |    |    |   |   |  |    |   |   |  |      |   |   |  |    |   |   |  |    |   |   |  |    |   |   |  |    |   |   |  |                                                                                                                                                                                                                                                                                                                                                                                                                                                 |    |   |   |    |    |   |   |  |    |   |   |  |      |   |   |  |    |   |   |  |    |   |   |  |    |   |   |  |    |   |   |  |
| M1     | 2                                                                                                                                                                                                                                                                                                                                                                                                                                               | ■      |               |               |    |    |   |   |  |    |   |   |  |      |   |   |  |    |   |   |  |    |   |   |  |    |   |   |  |    |   |   |  |                                                                                                                                                                                                                                                                                                                                                                                                                                                 |    |   |   |    |    |   |   |  |    |   |   |  |      |   |   |  |    |   |   |  |    |   |   |  |    |   |   |  |    |   |   |  |                                                                                                                                                                                                                                                                                                                                                                                                                                                 |    |   |   |    |    |   |   |  |    |   |   |  |      |   |   |  |    |   |   |  |    |   |   |  |    |   |   |  |    |   |   |  |                                                                                                                                                                                                                                                                                                                                                                                                                                                 |    |   |   |    |    |   |   |  |    |   |   |  |      |   |   |  |    |   |   |  |    |   |   |  |    |   |   |  |    |   |   |  |
| M2     | 3                                                                                                                                                                                                                                                                                                                                                                                                                                               | ■      |               |               |    |    |   |   |  |    |   |   |  |      |   |   |  |    |   |   |  |    |   |   |  |    |   |   |  |    |   |   |  |                                                                                                                                                                                                                                                                                                                                                                                                                                                 |    |   |   |    |    |   |   |  |    |   |   |  |      |   |   |  |    |   |   |  |    |   |   |  |    |   |   |  |    |   |   |  |                                                                                                                                                                                                                                                                                                                                                                                                                                                 |    |   |   |    |    |   |   |  |    |   |   |  |      |   |   |  |    |   |   |  |    |   |   |  |    |   |   |  |    |   |   |  |                                                                                                                                                                                                                                                                                                                                                                                                                                                 |    |   |   |    |    |   |   |  |    |   |   |  |      |   |   |  |    |   |   |  |    |   |   |  |    |   |   |  |    |   |   |  |
| TERM   | 4                                                                                                                                                                                                                                                                                                                                                                                                                                               | ■      |               |               |    |    |   |   |  |    |   |   |  |      |   |   |  |    |   |   |  |    |   |   |  |    |   |   |  |    |   |   |  |                                                                                                                                                                                                                                                                                                                                                                                                                                                 |    |   |   |    |    |   |   |  |    |   |   |  |      |   |   |  |    |   |   |  |    |   |   |  |    |   |   |  |    |   |   |  |                                                                                                                                                                                                                                                                                                                                                                                                                                                 |    |   |   |    |    |   |   |  |    |   |   |  |      |   |   |  |    |   |   |  |    |   |   |  |    |   |   |  |    |   |   |  |                                                                                                                                                                                                                                                                                                                                                                                                                                                 |    |   |   |    |    |   |   |  |    |   |   |  |      |   |   |  |    |   |   |  |    |   |   |  |    |   |   |  |    |   |   |  |
| T+     | 5                                                                                                                                                                                                                                                                                                                                                                                                                                               | ■      |               |               |    |    |   |   |  |    |   |   |  |      |   |   |  |    |   |   |  |    |   |   |  |    |   |   |  |    |   |   |  |                                                                                                                                                                                                                                                                                                                                                                                                                                                 |    |   |   |    |    |   |   |  |    |   |   |  |      |   |   |  |    |   |   |  |    |   |   |  |    |   |   |  |    |   |   |  |                                                                                                                                                                                                                                                                                                                                                                                                                                                 |    |   |   |    |    |   |   |  |    |   |   |  |      |   |   |  |    |   |   |  |    |   |   |  |    |   |   |  |    |   |   |  |                                                                                                                                                                                                                                                                                                                                                                                                                                                 |    |   |   |    |    |   |   |  |    |   |   |  |      |   |   |  |    |   |   |  |    |   |   |  |    |   |   |  |    |   |   |  |
| T-     | 6                                                                                                                                                                                                                                                                                                                                                                                                                                               | ■      |               |               |    |    |   |   |  |    |   |   |  |      |   |   |  |    |   |   |  |    |   |   |  |    |   |   |  |    |   |   |  |                                                                                                                                                                                                                                                                                                                                                                                                                                                 |    |   |   |    |    |   |   |  |    |   |   |  |      |   |   |  |    |   |   |  |    |   |   |  |    |   |   |  |    |   |   |  |                                                                                                                                                                                                                                                                                                                                                                                                                                                 |    |   |   |    |    |   |   |  |    |   |   |  |      |   |   |  |    |   |   |  |    |   |   |  |    |   |   |  |    |   |   |  |                                                                                                                                                                                                                                                                                                                                                                                                                                                 |    |   |   |    |    |   |   |  |    |   |   |  |      |   |   |  |    |   |   |  |    |   |   |  |    |   |   |  |    |   |   |  |
| R+     | 7                                                                                                                                                                                                                                                                                                                                                                                                                                               | ■      |               |               |    |    |   |   |  |    |   |   |  |      |   |   |  |    |   |   |  |    |   |   |  |    |   |   |  |    |   |   |  |                                                                                                                                                                                                                                                                                                                                                                                                                                                 |    |   |   |    |    |   |   |  |    |   |   |  |      |   |   |  |    |   |   |  |    |   |   |  |    |   |   |  |    |   |   |  |                                                                                                                                                                                                                                                                                                                                                                                                                                                 |    |   |   |    |    |   |   |  |    |   |   |  |      |   |   |  |    |   |   |  |    |   |   |  |    |   |   |  |    |   |   |  |                                                                                                                                                                                                                                                                                                                                                                                                                                                 |    |   |   |    |    |   |   |  |    |   |   |  |      |   |   |  |    |   |   |  |    |   |   |  |    |   |   |  |    |   |   |  |
| R-     | 8                                                                                                                                                                                                                                                                                                                                                                                                                                               | ■      |               |               |    |    |   |   |  |    |   |   |  |      |   |   |  |    |   |   |  |    |   |   |  |    |   |   |  |    |   |   |  |                                                                                                                                                                                                                                                                                                                                                                                                                                                 |    |   |   |    |    |   |   |  |    |   |   |  |      |   |   |  |    |   |   |  |    |   |   |  |    |   |   |  |    |   |   |  |                                                                                                                                                                                                                                                                                                                                                                                                                                                 |    |   |   |    |    |   |   |  |    |   |   |  |      |   |   |  |    |   |   |  |    |   |   |  |    |   |   |  |    |   |   |  |                                                                                                                                                                                                                                                                                                                                                                                                                                                 |    |   |   |    |    |   |   |  |    |   |   |  |      |   |   |  |    |   |   |  |    |   |   |  |    |   |   |  |    |   |   |  |
| M0     | 1                                                                                                                                                                                                                                                                                                                                                                                                                                               | ■      | ON            |               |    |    |   |   |  |    |   |   |  |      |   |   |  |    |   |   |  |    |   |   |  |    |   |   |  |    |   |   |  |                                                                                                                                                                                                                                                                                                                                                                                                                                                 |    |   |   |    |    |   |   |  |    |   |   |  |      |   |   |  |    |   |   |  |    |   |   |  |    |   |   |  |    |   |   |  |                                                                                                                                                                                                                                                                                                                                                                                                                                                 |    |   |   |    |    |   |   |  |    |   |   |  |      |   |   |  |    |   |   |  |    |   |   |  |    |   |   |  |    |   |   |  |                                                                                                                                                                                                                                                                                                                                                                                                                                                 |    |   |   |    |    |   |   |  |    |   |   |  |      |   |   |  |    |   |   |  |    |   |   |  |    |   |   |  |    |   |   |  |
| M1     | 2                                                                                                                                                                                                                                                                                                                                                                                                                                               | ■      |               |               |    |    |   |   |  |    |   |   |  |      |   |   |  |    |   |   |  |    |   |   |  |    |   |   |  |    |   |   |  |                                                                                                                                                                                                                                                                                                                                                                                                                                                 |    |   |   |    |    |   |   |  |    |   |   |  |      |   |   |  |    |   |   |  |    |   |   |  |    |   |   |  |    |   |   |  |                                                                                                                                                                                                                                                                                                                                                                                                                                                 |    |   |   |    |    |   |   |  |    |   |   |  |      |   |   |  |    |   |   |  |    |   |   |  |    |   |   |  |    |   |   |  |                                                                                                                                                                                                                                                                                                                                                                                                                                                 |    |   |   |    |    |   |   |  |    |   |   |  |      |   |   |  |    |   |   |  |    |   |   |  |    |   |   |  |    |   |   |  |
| M2     | 3                                                                                                                                                                                                                                                                                                                                                                                                                                               | ■      |               |               |    |    |   |   |  |    |   |   |  |      |   |   |  |    |   |   |  |    |   |   |  |    |   |   |  |    |   |   |  |                                                                                                                                                                                                                                                                                                                                                                                                                                                 |    |   |   |    |    |   |   |  |    |   |   |  |      |   |   |  |    |   |   |  |    |   |   |  |    |   |   |  |    |   |   |  |                                                                                                                                                                                                                                                                                                                                                                                                                                                 |    |   |   |    |    |   |   |  |    |   |   |  |      |   |   |  |    |   |   |  |    |   |   |  |    |   |   |  |    |   |   |  |                                                                                                                                                                                                                                                                                                                                                                                                                                                 |    |   |   |    |    |   |   |  |    |   |   |  |      |   |   |  |    |   |   |  |    |   |   |  |    |   |   |  |    |   |   |  |
| TERM   | 4                                                                                                                                                                                                                                                                                                                                                                                                                                               | ■      |               |               |    |    |   |   |  |    |   |   |  |      |   |   |  |    |   |   |  |    |   |   |  |    |   |   |  |    |   |   |  |                                                                                                                                                                                                                                                                                                                                                                                                                                                 |    |   |   |    |    |   |   |  |    |   |   |  |      |   |   |  |    |   |   |  |    |   |   |  |    |   |   |  |    |   |   |  |                                                                                                                                                                                                                                                                                                                                                                                                                                                 |    |   |   |    |    |   |   |  |    |   |   |  |      |   |   |  |    |   |   |  |    |   |   |  |    |   |   |  |    |   |   |  |                                                                                                                                                                                                                                                                                                                                                                                                                                                 |    |   |   |    |    |   |   |  |    |   |   |  |      |   |   |  |    |   |   |  |    |   |   |  |    |   |   |  |    |   |   |  |
| T+     | 5                                                                                                                                                                                                                                                                                                                                                                                                                                               | ■      |               |               |    |    |   |   |  |    |   |   |  |      |   |   |  |    |   |   |  |    |   |   |  |    |   |   |  |    |   |   |  |                                                                                                                                                                                                                                                                                                                                                                                                                                                 |    |   |   |    |    |   |   |  |    |   |   |  |      |   |   |  |    |   |   |  |    |   |   |  |    |   |   |  |    |   |   |  |                                                                                                                                                                                                                                                                                                                                                                                                                                                 |    |   |   |    |    |   |   |  |    |   |   |  |      |   |   |  |    |   |   |  |    |   |   |  |    |   |   |  |    |   |   |  |                                                                                                                                                                                                                                                                                                                                                                                                                                                 |    |   |   |    |    |   |   |  |    |   |   |  |      |   |   |  |    |   |   |  |    |   |   |  |    |   |   |  |    |   |   |  |
| T-     | 6                                                                                                                                                                                                                                                                                                                                                                                                                                               | ■      |               |               |    |    |   |   |  |    |   |   |  |      |   |   |  |    |   |   |  |    |   |   |  |    |   |   |  |    |   |   |  |                                                                                                                                                                                                                                                                                                                                                                                                                                                 |    |   |   |    |    |   |   |  |    |   |   |  |      |   |   |  |    |   |   |  |    |   |   |  |    |   |   |  |    |   |   |  |                                                                                                                                                                                                                                                                                                                                                                                                                                                 |    |   |   |    |    |   |   |  |    |   |   |  |      |   |   |  |    |   |   |  |    |   |   |  |    |   |   |  |    |   |   |  |                                                                                                                                                                                                                                                                                                                                                                                                                                                 |    |   |   |    |    |   |   |  |    |   |   |  |      |   |   |  |    |   |   |  |    |   |   |  |    |   |   |  |    |   |   |  |
| R+     | 7                                                                                                                                                                                                                                                                                                                                                                                                                                               | ■      |               |               |    |    |   |   |  |    |   |   |  |      |   |   |  |    |   |   |  |    |   |   |  |    |   |   |  |    |   |   |  |                                                                                                                                                                                                                                                                                                                                                                                                                                                 |    |   |   |    |    |   |   |  |    |   |   |  |      |   |   |  |    |   |   |  |    |   |   |  |    |   |   |  |    |   |   |  |                                                                                                                                                                                                                                                                                                                                                                                                                                                 |    |   |   |    |    |   |   |  |    |   |   |  |      |   |   |  |    |   |   |  |    |   |   |  |    |   |   |  |    |   |   |  |                                                                                                                                                                                                                                                                                                                                                                                                                                                 |    |   |   |    |    |   |   |  |    |   |   |  |      |   |   |  |    |   |   |  |    |   |   |  |    |   |   |  |    |   |   |  |
| R-     | 8                                                                                                                                                                                                                                                                                                                                                                                                                                               | ■      |               |               |    |    |   |   |  |    |   |   |  |      |   |   |  |    |   |   |  |    |   |   |  |    |   |   |  |    |   |   |  |                                                                                                                                                                                                                                                                                                                                                                                                                                                 |    |   |   |    |    |   |   |  |    |   |   |  |      |   |   |  |    |   |   |  |    |   |   |  |    |   |   |  |    |   |   |  |                                                                                                                                                                                                                                                                                                                                                                                                                                                 |    |   |   |    |    |   |   |  |    |   |   |  |      |   |   |  |    |   |   |  |    |   |   |  |    |   |   |  |    |   |   |  |                                                                                                                                                                                                                                                                                                                                                                                                                                                 |    |   |   |    |    |   |   |  |    |   |   |  |      |   |   |  |    |   |   |  |    |   |   |  |    |   |   |  |    |   |   |  |
| M0     | 1                                                                                                                                                                                                                                                                                                                                                                                                                                               | ■      | ON            |               |    |    |   |   |  |    |   |   |  |      |   |   |  |    |   |   |  |    |   |   |  |    |   |   |  |    |   |   |  |                                                                                                                                                                                                                                                                                                                                                                                                                                                 |    |   |   |    |    |   |   |  |    |   |   |  |      |   |   |  |    |   |   |  |    |   |   |  |    |   |   |  |    |   |   |  |                                                                                                                                                                                                                                                                                                                                                                                                                                                 |    |   |   |    |    |   |   |  |    |   |   |  |      |   |   |  |    |   |   |  |    |   |   |  |    |   |   |  |    |   |   |  |                                                                                                                                                                                                                                                                                                                                                                                                                                                 |    |   |   |    |    |   |   |  |    |   |   |  |      |   |   |  |    |   |   |  |    |   |   |  |    |   |   |  |    |   |   |  |
| M1     | 2                                                                                                                                                                                                                                                                                                                                                                                                                                               | ■      |               |               |    |    |   |   |  |    |   |   |  |      |   |   |  |    |   |   |  |    |   |   |  |    |   |   |  |    |   |   |  |                                                                                                                                                                                                                                                                                                                                                                                                                                                 |    |   |   |    |    |   |   |  |    |   |   |  |      |   |   |  |    |   |   |  |    |   |   |  |    |   |   |  |    |   |   |  |                                                                                                                                                                                                                                                                                                                                                                                                                                                 |    |   |   |    |    |   |   |  |    |   |   |  |      |   |   |  |    |   |   |  |    |   |   |  |    |   |   |  |    |   |   |  |                                                                                                                                                                                                                                                                                                                                                                                                                                                 |    |   |   |    |    |   |   |  |    |   |   |  |      |   |   |  |    |   |   |  |    |   |   |  |    |   |   |  |    |   |   |  |
| M2     | 3                                                                                                                                                                                                                                                                                                                                                                                                                                               | ■      |               |               |    |    |   |   |  |    |   |   |  |      |   |   |  |    |   |   |  |    |   |   |  |    |   |   |  |    |   |   |  |                                                                                                                                                                                                                                                                                                                                                                                                                                                 |    |   |   |    |    |   |   |  |    |   |   |  |      |   |   |  |    |   |   |  |    |   |   |  |    |   |   |  |    |   |   |  |                                                                                                                                                                                                                                                                                                                                                                                                                                                 |    |   |   |    |    |   |   |  |    |   |   |  |      |   |   |  |    |   |   |  |    |   |   |  |    |   |   |  |    |   |   |  |                                                                                                                                                                                                                                                                                                                                                                                                                                                 |    |   |   |    |    |   |   |  |    |   |   |  |      |   |   |  |    |   |   |  |    |   |   |  |    |   |   |  |    |   |   |  |
| TERM   | 4                                                                                                                                                                                                                                                                                                                                                                                                                                               | ■      |               |               |    |    |   |   |  |    |   |   |  |      |   |   |  |    |   |   |  |    |   |   |  |    |   |   |  |    |   |   |  |                                                                                                                                                                                                                                                                                                                                                                                                                                                 |    |   |   |    |    |   |   |  |    |   |   |  |      |   |   |  |    |   |   |  |    |   |   |  |    |   |   |  |    |   |   |  |                                                                                                                                                                                                                                                                                                                                                                                                                                                 |    |   |   |    |    |   |   |  |    |   |   |  |      |   |   |  |    |   |   |  |    |   |   |  |    |   |   |  |    |   |   |  |                                                                                                                                                                                                                                                                                                                                                                                                                                                 |    |   |   |    |    |   |   |  |    |   |   |  |      |   |   |  |    |   |   |  |    |   |   |  |    |   |   |  |    |   |   |  |
| T+     | 5                                                                                                                                                                                                                                                                                                                                                                                                                                               | ■      |               |               |    |    |   |   |  |    |   |   |  |      |   |   |  |    |   |   |  |    |   |   |  |    |   |   |  |    |   |   |  |                                                                                                                                                                                                                                                                                                                                                                                                                                                 |    |   |   |    |    |   |   |  |    |   |   |  |      |   |   |  |    |   |   |  |    |   |   |  |    |   |   |  |    |   |   |  |                                                                                                                                                                                                                                                                                                                                                                                                                                                 |    |   |   |    |    |   |   |  |    |   |   |  |      |   |   |  |    |   |   |  |    |   |   |  |    |   |   |  |    |   |   |  |                                                                                                                                                                                                                                                                                                                                                                                                                                                 |    |   |   |    |    |   |   |  |    |   |   |  |      |   |   |  |    |   |   |  |    |   |   |  |    |   |   |  |    |   |   |  |
| T-     | 6                                                                                                                                                                                                                                                                                                                                                                                                                                               | ■      |               |               |    |    |   |   |  |    |   |   |  |      |   |   |  |    |   |   |  |    |   |   |  |    |   |   |  |    |   |   |  |                                                                                                                                                                                                                                                                                                                                                                                                                                                 |    |   |   |    |    |   |   |  |    |   |   |  |      |   |   |  |    |   |   |  |    |   |   |  |    |   |   |  |    |   |   |  |                                                                                                                                                                                                                                                                                                                                                                                                                                                 |    |   |   |    |    |   |   |  |    |   |   |  |      |   |   |  |    |   |   |  |    |   |   |  |    |   |   |  |    |   |   |  |                                                                                                                                                                                                                                                                                                                                                                                                                                                 |    |   |   |    |    |   |   |  |    |   |   |  |      |   |   |  |    |   |   |  |    |   |   |  |    |   |   |  |    |   |   |  |
| R+     | 7                                                                                                                                                                                                                                                                                                                                                                                                                                               | ■      |               |               |    |    |   |   |  |    |   |   |  |      |   |   |  |    |   |   |  |    |   |   |  |    |   |   |  |    |   |   |  |                                                                                                                                                                                                                                                                                                                                                                                                                                                 |    |   |   |    |    |   |   |  |    |   |   |  |      |   |   |  |    |   |   |  |    |   |   |  |    |   |   |  |    |   |   |  |                                                                                                                                                                                                                                                                                                                                                                                                                                                 |    |   |   |    |    |   |   |  |    |   |   |  |      |   |   |  |    |   |   |  |    |   |   |  |    |   |   |  |    |   |   |  |                                                                                                                                                                                                                                                                                                                                                                                                                                                 |    |   |   |    |    |   |   |  |    |   |   |  |      |   |   |  |    |   |   |  |    |   |   |  |    |   |   |  |    |   |   |  |
| R-     | 8                                                                                                                                                                                                                                                                                                                                                                                                                                               | ■      |               |               |    |    |   |   |  |    |   |   |  |      |   |   |  |    |   |   |  |    |   |   |  |    |   |   |  |    |   |   |  |                                                                                                                                                                                                                                                                                                                                                                                                                                                 |    |   |   |    |    |   |   |  |    |   |   |  |      |   |   |  |    |   |   |  |    |   |   |  |    |   |   |  |    |   |   |  |                                                                                                                                                                                                                                                                                                                                                                                                                                                 |    |   |   |    |    |   |   |  |    |   |   |  |      |   |   |  |    |   |   |  |    |   |   |  |    |   |   |  |    |   |   |  |                                                                                                                                                                                                                                                                                                                                                                                                                                                 |    |   |   |    |    |   |   |  |    |   |   |  |      |   |   |  |    |   |   |  |    |   |   |  |    |   |   |  |    |   |   |  |
| M0     | 1                                                                                                                                                                                                                                                                                                                                                                                                                                               | ■      | ON            |               |    |    |   |   |  |    |   |   |  |      |   |   |  |    |   |   |  |    |   |   |  |    |   |   |  |    |   |   |  |                                                                                                                                                                                                                                                                                                                                                                                                                                                 |    |   |   |    |    |   |   |  |    |   |   |  |      |   |   |  |    |   |   |  |    |   |   |  |    |   |   |  |    |   |   |  |                                                                                                                                                                                                                                                                                                                                                                                                                                                 |    |   |   |    |    |   |   |  |    |   |   |  |      |   |   |  |    |   |   |  |    |   |   |  |    |   |   |  |    |   |   |  |                                                                                                                                                                                                                                                                                                                                                                                                                                                 |    |   |   |    |    |   |   |  |    |   |   |  |      |   |   |  |    |   |   |  |    |   |   |  |    |   |   |  |    |   |   |  |
| M1     | 2                                                                                                                                                                                                                                                                                                                                                                                                                                               | ■      |               |               |    |    |   |   |  |    |   |   |  |      |   |   |  |    |   |   |  |    |   |   |  |    |   |   |  |    |   |   |  |                                                                                                                                                                                                                                                                                                                                                                                                                                                 |    |   |   |    |    |   |   |  |    |   |   |  |      |   |   |  |    |   |   |  |    |   |   |  |    |   |   |  |    |   |   |  |                                                                                                                                                                                                                                                                                                                                                                                                                                                 |    |   |   |    |    |   |   |  |    |   |   |  |      |   |   |  |    |   |   |  |    |   |   |  |    |   |   |  |    |   |   |  |                                                                                                                                                                                                                                                                                                                                                                                                                                                 |    |   |   |    |    |   |   |  |    |   |   |  |      |   |   |  |    |   |   |  |    |   |   |  |    |   |   |  |    |   |   |  |
| M2     | 3                                                                                                                                                                                                                                                                                                                                                                                                                                               | ■      |               |               |    |    |   |   |  |    |   |   |  |      |   |   |  |    |   |   |  |    |   |   |  |    |   |   |  |    |   |   |  |                                                                                                                                                                                                                                                                                                                                                                                                                                                 |    |   |   |    |    |   |   |  |    |   |   |  |      |   |   |  |    |   |   |  |    |   |   |  |    |   |   |  |    |   |   |  |                                                                                                                                                                                                                                                                                                                                                                                                                                                 |    |   |   |    |    |   |   |  |    |   |   |  |      |   |   |  |    |   |   |  |    |   |   |  |    |   |   |  |    |   |   |  |                                                                                                                                                                                                                                                                                                                                                                                                                                                 |    |   |   |    |    |   |   |  |    |   |   |  |      |   |   |  |    |   |   |  |    |   |   |  |    |   |   |  |    |   |   |  |
| TERM   | 4                                                                                                                                                                                                                                                                                                                                                                                                                                               | ■      |               |               |    |    |   |   |  |    |   |   |  |      |   |   |  |    |   |   |  |    |   |   |  |    |   |   |  |    |   |   |  |                                                                                                                                                                                                                                                                                                                                                                                                                                                 |    |   |   |    |    |   |   |  |    |   |   |  |      |   |   |  |    |   |   |  |    |   |   |  |    |   |   |  |    |   |   |  |                                                                                                                                                                                                                                                                                                                                                                                                                                                 |    |   |   |    |    |   |   |  |    |   |   |  |      |   |   |  |    |   |   |  |    |   |   |  |    |   |   |  |    |   |   |  |                                                                                                                                                                                                                                                                                                                                                                                                                                                 |    |   |   |    |    |   |   |  |    |   |   |  |      |   |   |  |    |   |   |  |    |   |   |  |    |   |   |  |    |   |   |  |
| T+     | 5                                                                                                                                                                                                                                                                                                                                                                                                                                               | ■      |               |               |    |    |   |   |  |    |   |   |  |      |   |   |  |    |   |   |  |    |   |   |  |    |   |   |  |    |   |   |  |                                                                                                                                                                                                                                                                                                                                                                                                                                                 |    |   |   |    |    |   |   |  |    |   |   |  |      |   |   |  |    |   |   |  |    |   |   |  |    |   |   |  |    |   |   |  |                                                                                                                                                                                                                                                                                                                                                                                                                                                 |    |   |   |    |    |   |   |  |    |   |   |  |      |   |   |  |    |   |   |  |    |   |   |  |    |   |   |  |    |   |   |  |                                                                                                                                                                                                                                                                                                                                                                                                                                                 |    |   |   |    |    |   |   |  |    |   |   |  |      |   |   |  |    |   |   |  |    |   |   |  |    |   |   |  |    |   |   |  |
| T-     | 6                                                                                                                                                                                                                                                                                                                                                                                                                                               | ■      |               |               |    |    |   |   |  |    |   |   |  |      |   |   |  |    |   |   |  |    |   |   |  |    |   |   |  |    |   |   |  |                                                                                                                                                                                                                                                                                                                                                                                                                                                 |    |   |   |    |    |   |   |  |    |   |   |  |      |   |   |  |    |   |   |  |    |   |   |  |    |   |   |  |    |   |   |  |                                                                                                                                                                                                                                                                                                                                                                                                                                                 |    |   |   |    |    |   |   |  |    |   |   |  |      |   |   |  |    |   |   |  |    |   |   |  |    |   |   |  |    |   |   |  |                                                                                                                                                                                                                                                                                                                                                                                                                                                 |    |   |   |    |    |   |   |  |    |   |   |  |      |   |   |  |    |   |   |  |    |   |   |  |    |   |   |  |    |   |   |  |
| R+     | 7                                                                                                                                                                                                                                                                                                                                                                                                                                               | ■      |               |               |    |    |   |   |  |    |   |   |  |      |   |   |  |    |   |   |  |    |   |   |  |    |   |   |  |    |   |   |  |                                                                                                                                                                                                                                                                                                                                                                                                                                                 |    |   |   |    |    |   |   |  |    |   |   |  |      |   |   |  |    |   |   |  |    |   |   |  |    |   |   |  |    |   |   |  |                                                                                                                                                                                                                                                                                                                                                                                                                                                 |    |   |   |    |    |   |   |  |    |   |   |  |      |   |   |  |    |   |   |  |    |   |   |  |    |   |   |  |    |   |   |  |                                                                                                                                                                                                                                                                                                                                                                                                                                                 |    |   |   |    |    |   |   |  |    |   |   |  |      |   |   |  |    |   |   |  |    |   |   |  |    |   |   |  |    |   |   |  |
| R-     | 8                                                                                                                                                                                                                                                                                                                                                                                                                                               | ■      |               |               |    |    |   |   |  |    |   |   |  |      |   |   |  |    |   |   |  |    |   |   |  |    |   |   |  |    |   |   |  |                                                                                                                                                                                                                                                                                                                                                                                                                                                 |    |   |   |    |    |   |   |  |    |   |   |  |      |   |   |  |    |   |   |  |    |   |   |  |    |   |   |  |    |   |   |  |                                                                                                                                                                                                                                                                                                                                                                                                                                                 |    |   |   |    |    |   |   |  |    |   |   |  |      |   |   |  |    |   |   |  |    |   |   |  |    |   |   |  |    |   |   |  |                                                                                                                                                                                                                                                                                                                                                                                                                                                 |    |   |   |    |    |   |   |  |    |   |   |  |      |   |   |  |    |   |   |  |    |   |   |  |    |   |   |  |    |   |   |  |
| Port 4 | <table border="1"> <tr><td>M0</td><td>1</td><td>■</td><td>ON</td></tr> <tr><td>M1</td><td>2</td><td>■</td><td></td></tr> <tr><td>M2</td><td>3</td><td>■</td><td></td></tr> <tr><td>TERM</td><td>4</td><td>■</td><td></td></tr> <tr><td>T+</td><td>5</td><td>■</td><td></td></tr> <tr><td>T-</td><td>6</td><td>■</td><td></td></tr> <tr><td>R+</td><td>7</td><td>■</td><td></td></tr> <tr><td>R-</td><td>8</td><td>■</td><td></td></tr> </table> | M0     | 1             | ■             | ON | M1 | 2 | ■ |  | M2 | 3 | ■ |  | TERM | 4 | ■ |  | T+ | 5 | ■ |  | T- | 6 | ■ |  | R+ | 7 | ■ |  | R- | 8 | ■ |  | <table border="1"> <tr><td>M0</td><td>1</td><td>■</td><td>ON</td></tr> <tr><td>M1</td><td>2</td><td>■</td><td></td></tr> <tr><td>M2</td><td>3</td><td>■</td><td></td></tr> <tr><td>TERM</td><td>4</td><td>■</td><td></td></tr> <tr><td>T+</td><td>5</td><td>■</td><td></td></tr> <tr><td>T-</td><td>6</td><td>■</td><td></td></tr> <tr><td>R+</td><td>7</td><td>■</td><td></td></tr> <tr><td>R-</td><td>8</td><td>■</td><td></td></tr> </table> | M0 | 1 | ■ | ON | M1 | 2 | ■ |  | M2 | 3 | ■ |  | TERM | 4 | ■ |  | T+ | 5 | ■ |  | T- | 6 | ■ |  | R+ | 7 | ■ |  | R- | 8 | ■ |  | <table border="1"> <tr><td>M0</td><td>1</td><td>■</td><td>ON</td></tr> <tr><td>M1</td><td>2</td><td>■</td><td></td></tr> <tr><td>M2</td><td>3</td><td>■</td><td></td></tr> <tr><td>TERM</td><td>4</td><td>■</td><td></td></tr> <tr><td>T+</td><td>5</td><td>■</td><td></td></tr> <tr><td>T-</td><td>6</td><td>■</td><td></td></tr> <tr><td>R+</td><td>7</td><td>■</td><td></td></tr> <tr><td>R-</td><td>8</td><td>■</td><td></td></tr> </table> | M0 | 1 | ■ | ON | M1 | 2 | ■ |  | M2 | 3 | ■ |  | TERM | 4 | ■ |  | T+ | 5 | ■ |  | T- | 6 | ■ |  | R+ | 7 | ■ |  | R- | 8 | ■ |  | <table border="1"> <tr><td>M0</td><td>1</td><td>■</td><td>ON</td></tr> <tr><td>M1</td><td>2</td><td>■</td><td></td></tr> <tr><td>M2</td><td>3</td><td>■</td><td></td></tr> <tr><td>TERM</td><td>4</td><td>■</td><td></td></tr> <tr><td>T+</td><td>5</td><td>■</td><td></td></tr> <tr><td>T-</td><td>6</td><td>■</td><td></td></tr> <tr><td>R+</td><td>7</td><td>■</td><td></td></tr> <tr><td>R-</td><td>8</td><td>■</td><td></td></tr> </table> | M0 | 1 | ■ | ON | M1 | 2 | ■ |  | M2 | 3 | ■ |  | TERM | 4 | ■ |  | T+ | 5 | ■ |  | T- | 6 | ■ |  | R+ | 7 | ■ |  | R- | 8 | ■ |  |
| M0     | 1                                                                                                                                                                                                                                                                                                                                                                                                                                               | ■      | ON            |               |    |    |   |   |  |    |   |   |  |      |   |   |  |    |   |   |  |    |   |   |  |    |   |   |  |    |   |   |  |                                                                                                                                                                                                                                                                                                                                                                                                                                                 |    |   |   |    |    |   |   |  |    |   |   |  |      |   |   |  |    |   |   |  |    |   |   |  |    |   |   |  |    |   |   |  |                                                                                                                                                                                                                                                                                                                                                                                                                                                 |    |   |   |    |    |   |   |  |    |   |   |  |      |   |   |  |    |   |   |  |    |   |   |  |    |   |   |  |    |   |   |  |                                                                                                                                                                                                                                                                                                                                                                                                                                                 |    |   |   |    |    |   |   |  |    |   |   |  |      |   |   |  |    |   |   |  |    |   |   |  |    |   |   |  |    |   |   |  |
| M1     | 2                                                                                                                                                                                                                                                                                                                                                                                                                                               | ■      |               |               |    |    |   |   |  |    |   |   |  |      |   |   |  |    |   |   |  |    |   |   |  |    |   |   |  |    |   |   |  |                                                                                                                                                                                                                                                                                                                                                                                                                                                 |    |   |   |    |    |   |   |  |    |   |   |  |      |   |   |  |    |   |   |  |    |   |   |  |    |   |   |  |    |   |   |  |                                                                                                                                                                                                                                                                                                                                                                                                                                                 |    |   |   |    |    |   |   |  |    |   |   |  |      |   |   |  |    |   |   |  |    |   |   |  |    |   |   |  |    |   |   |  |                                                                                                                                                                                                                                                                                                                                                                                                                                                 |    |   |   |    |    |   |   |  |    |   |   |  |      |   |   |  |    |   |   |  |    |   |   |  |    |   |   |  |    |   |   |  |
| M2     | 3                                                                                                                                                                                                                                                                                                                                                                                                                                               | ■      |               |               |    |    |   |   |  |    |   |   |  |      |   |   |  |    |   |   |  |    |   |   |  |    |   |   |  |    |   |   |  |                                                                                                                                                                                                                                                                                                                                                                                                                                                 |    |   |   |    |    |   |   |  |    |   |   |  |      |   |   |  |    |   |   |  |    |   |   |  |    |   |   |  |    |   |   |  |                                                                                                                                                                                                                                                                                                                                                                                                                                                 |    |   |   |    |    |   |   |  |    |   |   |  |      |   |   |  |    |   |   |  |    |   |   |  |    |   |   |  |    |   |   |  |                                                                                                                                                                                                                                                                                                                                                                                                                                                 |    |   |   |    |    |   |   |  |    |   |   |  |      |   |   |  |    |   |   |  |    |   |   |  |    |   |   |  |    |   |   |  |
| TERM   | 4                                                                                                                                                                                                                                                                                                                                                                                                                                               | ■      |               |               |    |    |   |   |  |    |   |   |  |      |   |   |  |    |   |   |  |    |   |   |  |    |   |   |  |    |   |   |  |                                                                                                                                                                                                                                                                                                                                                                                                                                                 |    |   |   |    |    |   |   |  |    |   |   |  |      |   |   |  |    |   |   |  |    |   |   |  |    |   |   |  |    |   |   |  |                                                                                                                                                                                                                                                                                                                                                                                                                                                 |    |   |   |    |    |   |   |  |    |   |   |  |      |   |   |  |    |   |   |  |    |   |   |  |    |   |   |  |    |   |   |  |                                                                                                                                                                                                                                                                                                                                                                                                                                                 |    |   |   |    |    |   |   |  |    |   |   |  |      |   |   |  |    |   |   |  |    |   |   |  |    |   |   |  |    |   |   |  |
| T+     | 5                                                                                                                                                                                                                                                                                                                                                                                                                                               | ■      |               |               |    |    |   |   |  |    |   |   |  |      |   |   |  |    |   |   |  |    |   |   |  |    |   |   |  |    |   |   |  |                                                                                                                                                                                                                                                                                                                                                                                                                                                 |    |   |   |    |    |   |   |  |    |   |   |  |      |   |   |  |    |   |   |  |    |   |   |  |    |   |   |  |    |   |   |  |                                                                                                                                                                                                                                                                                                                                                                                                                                                 |    |   |   |    |    |   |   |  |    |   |   |  |      |   |   |  |    |   |   |  |    |   |   |  |    |   |   |  |    |   |   |  |                                                                                                                                                                                                                                                                                                                                                                                                                                                 |    |   |   |    |    |   |   |  |    |   |   |  |      |   |   |  |    |   |   |  |    |   |   |  |    |   |   |  |    |   |   |  |
| T-     | 6                                                                                                                                                                                                                                                                                                                                                                                                                                               | ■      |               |               |    |    |   |   |  |    |   |   |  |      |   |   |  |    |   |   |  |    |   |   |  |    |   |   |  |    |   |   |  |                                                                                                                                                                                                                                                                                                                                                                                                                                                 |    |   |   |    |    |   |   |  |    |   |   |  |      |   |   |  |    |   |   |  |    |   |   |  |    |   |   |  |    |   |   |  |                                                                                                                                                                                                                                                                                                                                                                                                                                                 |    |   |   |    |    |   |   |  |    |   |   |  |      |   |   |  |    |   |   |  |    |   |   |  |    |   |   |  |    |   |   |  |                                                                                                                                                                                                                                                                                                                                                                                                                                                 |    |   |   |    |    |   |   |  |    |   |   |  |      |   |   |  |    |   |   |  |    |   |   |  |    |   |   |  |    |   |   |  |
| R+     | 7                                                                                                                                                                                                                                                                                                                                                                                                                                               | ■      |               |               |    |    |   |   |  |    |   |   |  |      |   |   |  |    |   |   |  |    |   |   |  |    |   |   |  |    |   |   |  |                                                                                                                                                                                                                                                                                                                                                                                                                                                 |    |   |   |    |    |   |   |  |    |   |   |  |      |   |   |  |    |   |   |  |    |   |   |  |    |   |   |  |    |   |   |  |                                                                                                                                                                                                                                                                                                                                                                                                                                                 |    |   |   |    |    |   |   |  |    |   |   |  |      |   |   |  |    |   |   |  |    |   |   |  |    |   |   |  |    |   |   |  |                                                                                                                                                                                                                                                                                                                                                                                                                                                 |    |   |   |    |    |   |   |  |    |   |   |  |      |   |   |  |    |   |   |  |    |   |   |  |    |   |   |  |    |   |   |  |
| R-     | 8                                                                                                                                                                                                                                                                                                                                                                                                                                               | ■      |               |               |    |    |   |   |  |    |   |   |  |      |   |   |  |    |   |   |  |    |   |   |  |    |   |   |  |    |   |   |  |                                                                                                                                                                                                                                                                                                                                                                                                                                                 |    |   |   |    |    |   |   |  |    |   |   |  |      |   |   |  |    |   |   |  |    |   |   |  |    |   |   |  |    |   |   |  |                                                                                                                                                                                                                                                                                                                                                                                                                                                 |    |   |   |    |    |   |   |  |    |   |   |  |      |   |   |  |    |   |   |  |    |   |   |  |    |   |   |  |    |   |   |  |                                                                                                                                                                                                                                                                                                                                                                                                                                                 |    |   |   |    |    |   |   |  |    |   |   |  |      |   |   |  |    |   |   |  |    |   |   |  |    |   |   |  |    |   |   |  |
| M0     | 1                                                                                                                                                                                                                                                                                                                                                                                                                                               | ■      | ON            |               |    |    |   |   |  |    |   |   |  |      |   |   |  |    |   |   |  |    |   |   |  |    |   |   |  |    |   |   |  |                                                                                                                                                                                                                                                                                                                                                                                                                                                 |    |   |   |    |    |   |   |  |    |   |   |  |      |   |   |  |    |   |   |  |    |   |   |  |    |   |   |  |    |   |   |  |                                                                                                                                                                                                                                                                                                                                                                                                                                                 |    |   |   |    |    |   |   |  |    |   |   |  |      |   |   |  |    |   |   |  |    |   |   |  |    |   |   |  |    |   |   |  |                                                                                                                                                                                                                                                                                                                                                                                                                                                 |    |   |   |    |    |   |   |  |    |   |   |  |      |   |   |  |    |   |   |  |    |   |   |  |    |   |   |  |    |   |   |  |
| M1     | 2                                                                                                                                                                                                                                                                                                                                                                                                                                               | ■      |               |               |    |    |   |   |  |    |   |   |  |      |   |   |  |    |   |   |  |    |   |   |  |    |   |   |  |    |   |   |  |                                                                                                                                                                                                                                                                                                                                                                                                                                                 |    |   |   |    |    |   |   |  |    |   |   |  |      |   |   |  |    |   |   |  |    |   |   |  |    |   |   |  |    |   |   |  |                                                                                                                                                                                                                                                                                                                                                                                                                                                 |    |   |   |    |    |   |   |  |    |   |   |  |      |   |   |  |    |   |   |  |    |   |   |  |    |   |   |  |    |   |   |  |                                                                                                                                                                                                                                                                                                                                                                                                                                                 |    |   |   |    |    |   |   |  |    |   |   |  |      |   |   |  |    |   |   |  |    |   |   |  |    |   |   |  |    |   |   |  |
| M2     | 3                                                                                                                                                                                                                                                                                                                                                                                                                                               | ■      |               |               |    |    |   |   |  |    |   |   |  |      |   |   |  |    |   |   |  |    |   |   |  |    |   |   |  |    |   |   |  |                                                                                                                                                                                                                                                                                                                                                                                                                                                 |    |   |   |    |    |   |   |  |    |   |   |  |      |   |   |  |    |   |   |  |    |   |   |  |    |   |   |  |    |   |   |  |                                                                                                                                                                                                                                                                                                                                                                                                                                                 |    |   |   |    |    |   |   |  |    |   |   |  |      |   |   |  |    |   |   |  |    |   |   |  |    |   |   |  |    |   |   |  |                                                                                                                                                                                                                                                                                                                                                                                                                                                 |    |   |   |    |    |   |   |  |    |   |   |  |      |   |   |  |    |   |   |  |    |   |   |  |    |   |   |  |    |   |   |  |
| TERM   | 4                                                                                                                                                                                                                                                                                                                                                                                                                                               | ■      |               |               |    |    |   |   |  |    |   |   |  |      |   |   |  |    |   |   |  |    |   |   |  |    |   |   |  |    |   |   |  |                                                                                                                                                                                                                                                                                                                                                                                                                                                 |    |   |   |    |    |   |   |  |    |   |   |  |      |   |   |  |    |   |   |  |    |   |   |  |    |   |   |  |    |   |   |  |                                                                                                                                                                                                                                                                                                                                                                                                                                                 |    |   |   |    |    |   |   |  |    |   |   |  |      |   |   |  |    |   |   |  |    |   |   |  |    |   |   |  |    |   |   |  |                                                                                                                                                                                                                                                                                                                                                                                                                                                 |    |   |   |    |    |   |   |  |    |   |   |  |      |   |   |  |    |   |   |  |    |   |   |  |    |   |   |  |    |   |   |  |
| T+     | 5                                                                                                                                                                                                                                                                                                                                                                                                                                               | ■      |               |               |    |    |   |   |  |    |   |   |  |      |   |   |  |    |   |   |  |    |   |   |  |    |   |   |  |    |   |   |  |                                                                                                                                                                                                                                                                                                                                                                                                                                                 |    |   |   |    |    |   |   |  |    |   |   |  |      |   |   |  |    |   |   |  |    |   |   |  |    |   |   |  |    |   |   |  |                                                                                                                                                                                                                                                                                                                                                                                                                                                 |    |   |   |    |    |   |   |  |    |   |   |  |      |   |   |  |    |   |   |  |    |   |   |  |    |   |   |  |    |   |   |  |                                                                                                                                                                                                                                                                                                                                                                                                                                                 |    |   |   |    |    |   |   |  |    |   |   |  |      |   |   |  |    |   |   |  |    |   |   |  |    |   |   |  |    |   |   |  |
| T-     | 6                                                                                                                                                                                                                                                                                                                                                                                                                                               | ■      |               |               |    |    |   |   |  |    |   |   |  |      |   |   |  |    |   |   |  |    |   |   |  |    |   |   |  |    |   |   |  |                                                                                                                                                                                                                                                                                                                                                                                                                                                 |    |   |   |    |    |   |   |  |    |   |   |  |      |   |   |  |    |   |   |  |    |   |   |  |    |   |   |  |    |   |   |  |                                                                                                                                                                                                                                                                                                                                                                                                                                                 |    |   |   |    |    |   |   |  |    |   |   |  |      |   |   |  |    |   |   |  |    |   |   |  |    |   |   |  |    |   |   |  |                                                                                                                                                                                                                                                                                                                                                                                                                                                 |    |   |   |    |    |   |   |  |    |   |   |  |      |   |   |  |    |   |   |  |    |   |   |  |    |   |   |  |    |   |   |  |
| R+     | 7                                                                                                                                                                                                                                                                                                                                                                                                                                               | ■      |               |               |    |    |   |   |  |    |   |   |  |      |   |   |  |    |   |   |  |    |   |   |  |    |   |   |  |    |   |   |  |                                                                                                                                                                                                                                                                                                                                                                                                                                                 |    |   |   |    |    |   |   |  |    |   |   |  |      |   |   |  |    |   |   |  |    |   |   |  |    |   |   |  |    |   |   |  |                                                                                                                                                                                                                                                                                                                                                                                                                                                 |    |   |   |    |    |   |   |  |    |   |   |  |      |   |   |  |    |   |   |  |    |   |   |  |    |   |   |  |    |   |   |  |                                                                                                                                                                                                                                                                                                                                                                                                                                                 |    |   |   |    |    |   |   |  |    |   |   |  |      |   |   |  |    |   |   |  |    |   |   |  |    |   |   |  |    |   |   |  |
| R-     | 8                                                                                                                                                                                                                                                                                                                                                                                                                                               | ■      |               |               |    |    |   |   |  |    |   |   |  |      |   |   |  |    |   |   |  |    |   |   |  |    |   |   |  |    |   |   |  |                                                                                                                                                                                                                                                                                                                                                                                                                                                 |    |   |   |    |    |   |   |  |    |   |   |  |      |   |   |  |    |   |   |  |    |   |   |  |    |   |   |  |    |   |   |  |                                                                                                                                                                                                                                                                                                                                                                                                                                                 |    |   |   |    |    |   |   |  |    |   |   |  |      |   |   |  |    |   |   |  |    |   |   |  |    |   |   |  |    |   |   |  |                                                                                                                                                                                                                                                                                                                                                                                                                                                 |    |   |   |    |    |   |   |  |    |   |   |  |      |   |   |  |    |   |   |  |    |   |   |  |    |   |   |  |    |   |   |  |
| M0     | 1                                                                                                                                                                                                                                                                                                                                                                                                                                               | ■      | ON            |               |    |    |   |   |  |    |   |   |  |      |   |   |  |    |   |   |  |    |   |   |  |    |   |   |  |    |   |   |  |                                                                                                                                                                                                                                                                                                                                                                                                                                                 |    |   |   |    |    |   |   |  |    |   |   |  |      |   |   |  |    |   |   |  |    |   |   |  |    |   |   |  |    |   |   |  |                                                                                                                                                                                                                                                                                                                                                                                                                                                 |    |   |   |    |    |   |   |  |    |   |   |  |      |   |   |  |    |   |   |  |    |   |   |  |    |   |   |  |    |   |   |  |                                                                                                                                                                                                                                                                                                                                                                                                                                                 |    |   |   |    |    |   |   |  |    |   |   |  |      |   |   |  |    |   |   |  |    |   |   |  |    |   |   |  |    |   |   |  |
| M1     | 2                                                                                                                                                                                                                                                                                                                                                                                                                                               | ■      |               |               |    |    |   |   |  |    |   |   |  |      |   |   |  |    |   |   |  |    |   |   |  |    |   |   |  |    |   |   |  |                                                                                                                                                                                                                                                                                                                                                                                                                                                 |    |   |   |    |    |   |   |  |    |   |   |  |      |   |   |  |    |   |   |  |    |   |   |  |    |   |   |  |    |   |   |  |                                                                                                                                                                                                                                                                                                                                                                                                                                                 |    |   |   |    |    |   |   |  |    |   |   |  |      |   |   |  |    |   |   |  |    |   |   |  |    |   |   |  |    |   |   |  |                                                                                                                                                                                                                                                                                                                                                                                                                                                 |    |   |   |    |    |   |   |  |    |   |   |  |      |   |   |  |    |   |   |  |    |   |   |  |    |   |   |  |    |   |   |  |
| M2     | 3                                                                                                                                                                                                                                                                                                                                                                                                                                               | ■      |               |               |    |    |   |   |  |    |   |   |  |      |   |   |  |    |   |   |  |    |   |   |  |    |   |   |  |    |   |   |  |                                                                                                                                                                                                                                                                                                                                                                                                                                                 |    |   |   |    |    |   |   |  |    |   |   |  |      |   |   |  |    |   |   |  |    |   |   |  |    |   |   |  |    |   |   |  |                                                                                                                                                                                                                                                                                                                                                                                                                                                 |    |   |   |    |    |   |   |  |    |   |   |  |      |   |   |  |    |   |   |  |    |   |   |  |    |   |   |  |    |   |   |  |                                                                                                                                                                                                                                                                                                                                                                                                                                                 |    |   |   |    |    |   |   |  |    |   |   |  |      |   |   |  |    |   |   |  |    |   |   |  |    |   |   |  |    |   |   |  |
| TERM   | 4                                                                                                                                                                                                                                                                                                                                                                                                                                               | ■      |               |               |    |    |   |   |  |    |   |   |  |      |   |   |  |    |   |   |  |    |   |   |  |    |   |   |  |    |   |   |  |                                                                                                                                                                                                                                                                                                                                                                                                                                                 |    |   |   |    |    |   |   |  |    |   |   |  |      |   |   |  |    |   |   |  |    |   |   |  |    |   |   |  |    |   |   |  |                                                                                                                                                                                                                                                                                                                                                                                                                                                 |    |   |   |    |    |   |   |  |    |   |   |  |      |   |   |  |    |   |   |  |    |   |   |  |    |   |   |  |    |   |   |  |                                                                                                                                                                                                                                                                                                                                                                                                                                                 |    |   |   |    |    |   |   |  |    |   |   |  |      |   |   |  |    |   |   |  |    |   |   |  |    |   |   |  |    |   |   |  |
| T+     | 5                                                                                                                                                                                                                                                                                                                                                                                                                                               | ■      |               |               |    |    |   |   |  |    |   |   |  |      |   |   |  |    |   |   |  |    |   |   |  |    |   |   |  |    |   |   |  |                                                                                                                                                                                                                                                                                                                                                                                                                                                 |    |   |   |    |    |   |   |  |    |   |   |  |      |   |   |  |    |   |   |  |    |   |   |  |    |   |   |  |    |   |   |  |                                                                                                                                                                                                                                                                                                                                                                                                                                                 |    |   |   |    |    |   |   |  |    |   |   |  |      |   |   |  |    |   |   |  |    |   |   |  |    |   |   |  |    |   |   |  |                                                                                                                                                                                                                                                                                                                                                                                                                                                 |    |   |   |    |    |   |   |  |    |   |   |  |      |   |   |  |    |   |   |  |    |   |   |  |    |   |   |  |    |   |   |  |
| T-     | 6                                                                                                                                                                                                                                                                                                                                                                                                                                               | ■      |               |               |    |    |   |   |  |    |   |   |  |      |   |   |  |    |   |   |  |    |   |   |  |    |   |   |  |    |   |   |  |                                                                                                                                                                                                                                                                                                                                                                                                                                                 |    |   |   |    |    |   |   |  |    |   |   |  |      |   |   |  |    |   |   |  |    |   |   |  |    |   |   |  |    |   |   |  |                                                                                                                                                                                                                                                                                                                                                                                                                                                 |    |   |   |    |    |   |   |  |    |   |   |  |      |   |   |  |    |   |   |  |    |   |   |  |    |   |   |  |    |   |   |  |                                                                                                                                                                                                                                                                                                                                                                                                                                                 |    |   |   |    |    |   |   |  |    |   |   |  |      |   |   |  |    |   |   |  |    |   |   |  |    |   |   |  |    |   |   |  |
| R+     | 7                                                                                                                                                                                                                                                                                                                                                                                                                                               | ■      |               |               |    |    |   |   |  |    |   |   |  |      |   |   |  |    |   |   |  |    |   |   |  |    |   |   |  |    |   |   |  |                                                                                                                                                                                                                                                                                                                                                                                                                                                 |    |   |   |    |    |   |   |  |    |   |   |  |      |   |   |  |    |   |   |  |    |   |   |  |    |   |   |  |    |   |   |  |                                                                                                                                                                                                                                                                                                                                                                                                                                                 |    |   |   |    |    |   |   |  |    |   |   |  |      |   |   |  |    |   |   |  |    |   |   |  |    |   |   |  |    |   |   |  |                                                                                                                                                                                                                                                                                                                                                                                                                                                 |    |   |   |    |    |   |   |  |    |   |   |  |      |   |   |  |    |   |   |  |    |   |   |  |    |   |   |  |    |   |   |  |
| R-     | 8                                                                                                                                                                                                                                                                                                                                                                                                                                               | ■      |               |               |    |    |   |   |  |    |   |   |  |      |   |   |  |    |   |   |  |    |   |   |  |    |   |   |  |    |   |   |  |                                                                                                                                                                                                                                                                                                                                                                                                                                                 |    |   |   |    |    |   |   |  |    |   |   |  |      |   |   |  |    |   |   |  |    |   |   |  |    |   |   |  |    |   |   |  |                                                                                                                                                                                                                                                                                                                                                                                                                                                 |    |   |   |    |    |   |   |  |    |   |   |  |      |   |   |  |    |   |   |  |    |   |   |  |    |   |   |  |    |   |   |  |                                                                                                                                                                                                                                                                                                                                                                                                                                                 |    |   |   |    |    |   |   |  |    |   |   |  |      |   |   |  |    |   |   |  |    |   |   |  |    |   |   |  |    |   |   |  |
| M0     | 1                                                                                                                                                                                                                                                                                                                                                                                                                                               | ■      | ON            |               |    |    |   |   |  |    |   |   |  |      |   |   |  |    |   |   |  |    |   |   |  |    |   |   |  |    |   |   |  |                                                                                                                                                                                                                                                                                                                                                                                                                                                 |    |   |   |    |    |   |   |  |    |   |   |  |      |   |   |  |    |   |   |  |    |   |   |  |    |   |   |  |    |   |   |  |                                                                                                                                                                                                                                                                                                                                                                                                                                                 |    |   |   |    |    |   |   |  |    |   |   |  |      |   |   |  |    |   |   |  |    |   |   |  |    |   |   |  |    |   |   |  |                                                                                                                                                                                                                                                                                                                                                                                                                                                 |    |   |   |    |    |   |   |  |    |   |   |  |      |   |   |  |    |   |   |  |    |   |   |  |    |   |   |  |    |   |   |  |
| M1     | 2                                                                                                                                                                                                                                                                                                                                                                                                                                               | ■      |               |               |    |    |   |   |  |    |   |   |  |      |   |   |  |    |   |   |  |    |   |   |  |    |   |   |  |    |   |   |  |                                                                                                                                                                                                                                                                                                                                                                                                                                                 |    |   |   |    |    |   |   |  |    |   |   |  |      |   |   |  |    |   |   |  |    |   |   |  |    |   |   |  |    |   |   |  |                                                                                                                                                                                                                                                                                                                                                                                                                                                 |    |   |   |    |    |   |   |  |    |   |   |  |      |   |   |  |    |   |   |  |    |   |   |  |    |   |   |  |    |   |   |  |                                                                                                                                                                                                                                                                                                                                                                                                                                                 |    |   |   |    |    |   |   |  |    |   |   |  |      |   |   |  |    |   |   |  |    |   |   |  |    |   |   |  |    |   |   |  |
| M2     | 3                                                                                                                                                                                                                                                                                                                                                                                                                                               | ■      |               |               |    |    |   |   |  |    |   |   |  |      |   |   |  |    |   |   |  |    |   |   |  |    |   |   |  |    |   |   |  |                                                                                                                                                                                                                                                                                                                                                                                                                                                 |    |   |   |    |    |   |   |  |    |   |   |  |      |   |   |  |    |   |   |  |    |   |   |  |    |   |   |  |    |   |   |  |                                                                                                                                                                                                                                                                                                                                                                                                                                                 |    |   |   |    |    |   |   |  |    |   |   |  |      |   |   |  |    |   |   |  |    |   |   |  |    |   |   |  |    |   |   |  |                                                                                                                                                                                                                                                                                                                                                                                                                                                 |    |   |   |    |    |   |   |  |    |   |   |  |      |   |   |  |    |   |   |  |    |   |   |  |    |   |   |  |    |   |   |  |
| TERM   | 4                                                                                                                                                                                                                                                                                                                                                                                                                                               | ■      |               |               |    |    |   |   |  |    |   |   |  |      |   |   |  |    |   |   |  |    |   |   |  |    |   |   |  |    |   |   |  |                                                                                                                                                                                                                                                                                                                                                                                                                                                 |    |   |   |    |    |   |   |  |    |   |   |  |      |   |   |  |    |   |   |  |    |   |   |  |    |   |   |  |    |   |   |  |                                                                                                                                                                                                                                                                                                                                                                                                                                                 |    |   |   |    |    |   |   |  |    |   |   |  |      |   |   |  |    |   |   |  |    |   |   |  |    |   |   |  |    |   |   |  |                                                                                                                                                                                                                                                                                                                                                                                                                                                 |    |   |   |    |    |   |   |  |    |   |   |  |      |   |   |  |    |   |   |  |    |   |   |  |    |   |   |  |    |   |   |  |
| T+     | 5                                                                                                                                                                                                                                                                                                                                                                                                                                               | ■      |               |               |    |    |   |   |  |    |   |   |  |      |   |   |  |    |   |   |  |    |   |   |  |    |   |   |  |    |   |   |  |                                                                                                                                                                                                                                                                                                                                                                                                                                                 |    |   |   |    |    |   |   |  |    |   |   |  |      |   |   |  |    |   |   |  |    |   |   |  |    |   |   |  |    |   |   |  |                                                                                                                                                                                                                                                                                                                                                                                                                                                 |    |   |   |    |    |   |   |  |    |   |   |  |      |   |   |  |    |   |   |  |    |   |   |  |    |   |   |  |    |   |   |  |                                                                                                                                                                                                                                                                                                                                                                                                                                                 |    |   |   |    |    |   |   |  |    |   |   |  |      |   |   |  |    |   |   |  |    |   |   |  |    |   |   |  |    |   |   |  |
| T-     | 6                                                                                                                                                                                                                                                                                                                                                                                                                                               | ■      |               |               |    |    |   |   |  |    |   |   |  |      |   |   |  |    |   |   |  |    |   |   |  |    |   |   |  |    |   |   |  |                                                                                                                                                                                                                                                                                                                                                                                                                                                 |    |   |   |    |    |   |   |  |    |   |   |  |      |   |   |  |    |   |   |  |    |   |   |  |    |   |   |  |    |   |   |  |                                                                                                                                                                                                                                                                                                                                                                                                                                                 |    |   |   |    |    |   |   |  |    |   |   |  |      |   |   |  |    |   |   |  |    |   |   |  |    |   |   |  |    |   |   |  |                                                                                                                                                                                                                                                                                                                                                                                                                                                 |    |   |   |    |    |   |   |  |    |   |   |  |      |   |   |  |    |   |   |  |    |   |   |  |    |   |   |  |    |   |   |  |
| R+     | 7                                                                                                                                                                                                                                                                                                                                                                                                                                               | ■      |               |               |    |    |   |   |  |    |   |   |  |      |   |   |  |    |   |   |  |    |   |   |  |    |   |   |  |    |   |   |  |                                                                                                                                                                                                                                                                                                                                                                                                                                                 |    |   |   |    |    |   |   |  |    |   |   |  |      |   |   |  |    |   |   |  |    |   |   |  |    |   |   |  |    |   |   |  |                                                                                                                                                                                                                                                                                                                                                                                                                                                 |    |   |   |    |    |   |   |  |    |   |   |  |      |   |   |  |    |   |   |  |    |   |   |  |    |   |   |  |    |   |   |  |                                                                                                                                                                                                                                                                                                                                                                                                                                                 |    |   |   |    |    |   |   |  |    |   |   |  |      |   |   |  |    |   |   |  |    |   |   |  |    |   |   |  |    |   |   |  |
| R-     | 8                                                                                                                                                                                                                                                                                                                                                                                                                                               | ■      |               |               |    |    |   |   |  |    |   |   |  |      |   |   |  |    |   |   |  |    |   |   |  |    |   |   |  |    |   |   |  |                                                                                                                                                                                                                                                                                                                                                                                                                                                 |    |   |   |    |    |   |   |  |    |   |   |  |      |   |   |  |    |   |   |  |    |   |   |  |    |   |   |  |    |   |   |  |                                                                                                                                                                                                                                                                                                                                                                                                                                                 |    |   |   |    |    |   |   |  |    |   |   |  |      |   |   |  |    |   |   |  |    |   |   |  |    |   |   |  |    |   |   |  |                                                                                                                                                                                                                                                                                                                                                                                                                                                 |    |   |   |    |    |   |   |  |    |   |   |  |      |   |   |  |    |   |   |  |    |   |   |  |    |   |   |  |    |   |   |  |

## 4. Switch Settings

### Mode & Terminator Switch (S1-S4\_Mode)

Resistor Off

|      |         |    |
|------|---------|----|
| M0   |         | ON |
| M1   | 1 2 3 4 |    |
| M2   | 5 6 7 8 |    |
| TERM |         |    |
| T+   | ■       |    |
| T-   | ■       |    |
| R+   | ■       |    |
| R-   | ■       |    |

Resistor On

|      |         |    |
|------|---------|----|
| M0   |         | ON |
| M1   | 1 2 3 4 |    |
| M2   | 5 6 7 8 |    |
| TERM |         |    |
| T+   | ■       |    |
| T-   | ■       |    |
| R+   | ■       |    |
| R-   | ■       |    |

Terminator Off

|      |         |    |
|------|---------|----|
| M0   |         | ON |
| M1   | 1 2 3 4 | ■  |
| M2   | 5 6 7 8 |    |
| TERM |         |    |
| T+   |         |    |
| T-   |         |    |
| R+   |         |    |
| R-   |         |    |

Terminator On

|      |         |    |
|------|---------|----|
| M0   |         | ON |
| M1   | 1 2 3 4 | ■  |
| M2   | 5 6 7 8 |    |
| TERM |         |    |
| T+   |         |    |
| T-   |         |    |
| R+   |         |    |
| R-   |         |    |

Resistors for RS-422, RS-485 2-wire and RS-485 4-wire mode:

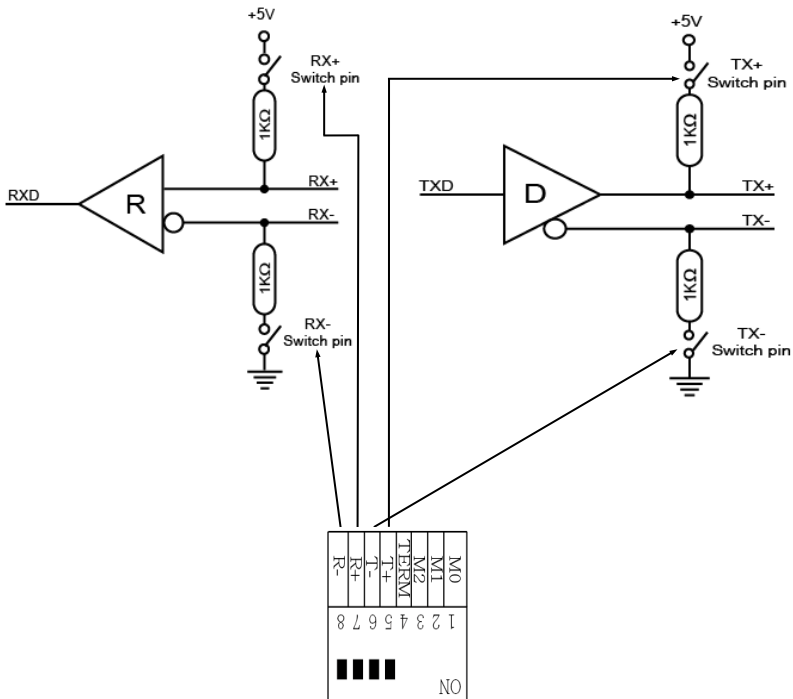



## 4. Switch Settings

Termination for RS-422, RS-485 2-wire and RS-485 4-wire mode:

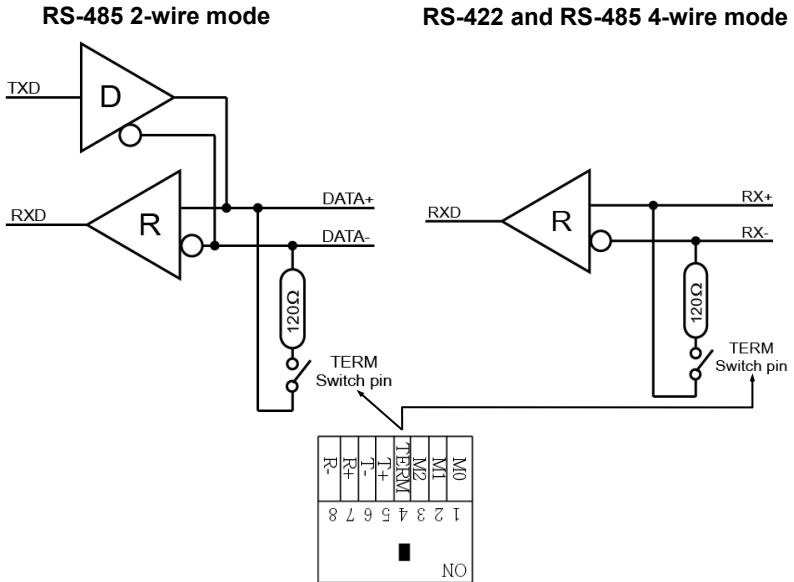

## 5. Hardware Installation

If you are ready with the jumper settings, please proceed with the following installation instructions. Because there are large differences between PC's, we can give you only a general installation guide for the EX-45034IS. Please refer to your computer's reference manual whenever in doubt.

1. Turn off the power to your computer and any other connected peripherals.
2. Remove the mounting screws located at the rear and/or sides panels of your Computer and gently slide the cover off.
3. Locate an available expansion slot and remove its covers from the rear panel of your computer. Make sure it is the right expansion slot for the card (see card description)
4. Align the card with the PCI-Express slot and then gently but firmly, insert the card. Make sure the card is seated and oriented correctly. Never insert the card by force!
5. First install the two 2x 9 pin brackets to the internal serial 10 pin headers S3 & S4.
6. Then connect the card with a screw to the rear panel of the computer case.
7. Gently replace your computer's cover and the mounting screws.

## 6. Driver Installation

### Windows

After completing the hardware installation, the operating system will automatically the card and install this! If the driver should not be installed automatically, you must manually install two drivers. One ist the USB host driver and the other is the USB to serial driver. for this insert the driver CD into you CD-ROM drive (eg drive D:) and then start the „**SETUP**“ which is located in folder „uPD720201\_202“ (see picture): Follow the hardware assistant and finish the installation. **Important!** Restart your PC in any case after installing the drivers.

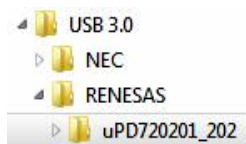

## 6. Driver Installation

### Windows

Second, please install now the USB to serial driver. Open the folder „USB\_to\_IO/FTDI“. Please select the folder with your operating system and install the driver (see Picture). Follow the hardware assistant and finish the installation. **Important!** Restart your PC in any case after installing the drivers.

Use the following driver for the following Windows Server Version:

|                       |   |                    |
|-----------------------|---|--------------------|
| Windows Server 2003   | = | XP Driver          |
| Windows Server 2008   | = | VISTA Driver       |
| Windows Server 2008R2 | = | Windows 7 Driver   |
| Windows Server 2012   | = | Windows 8.x Driver |
| Windows Server 2012R2 | = | Windows 10 Driver  |

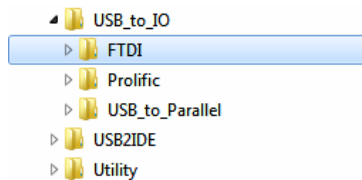

### CHECK INSTALLED DRIVER

Open the >**Device manager**<. Now you should see at „**Ports (COM & LPT)**“ and at „**USB-Controller**“ the following new entry's:

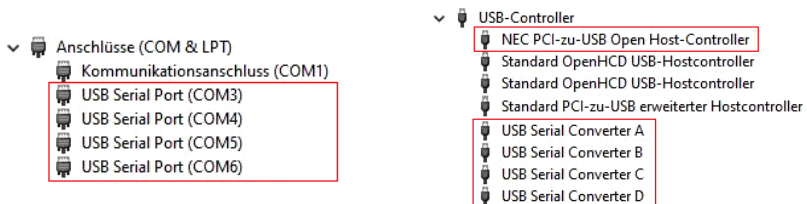

If you see this or a similar information the device is installed correctly.

### CHANGE PORT NUMBER

If you like to change the port number for example COM3 to COM5, open the „**Device Manager**“ click at „**COM3**“, „**Settings**“ and then „**Advance**“. There you can change between COM3 till COM256.

## 6. Driver Installation

### Linux & Mac OS

The drivers for Linux & Mac OS systems are also in the same folder „USB\_to\_IO/FTDI“. Please select the folder with your operating system and install the driver (see Picture).

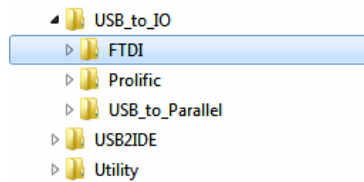

Because each individual distribution and kernel version of Linux is different, sadly we can't provide a installation instruction. Please refer to the installation manual for standard I/O ports from your Linux/Unix version! In some newer versions of Linux the card will even be installed automatically after starting Linux.

## 7. Technical Information

|                               |                                                                    |
|-------------------------------|--------------------------------------------------------------------|
| <b>Chip-Set:</b>              | FTDI                                                               |
| <b>Data Transfer Rate:</b>    | 300 Baud up to 921.6 KBAud                                         |
| <b>Connectors:</b>            | 4x 9 Pin serial RS-232 Connector                                   |
| <b>Hardware System:</b>       | PCI-Express x1 to x16                                              |
| <b>Operating System:</b>      | Windows 200x/ XP/ Vista/ 7/ 8.x/ 10/ Server 200xx<br>Linux/ Mac OS |
| <b>Operating Temperature:</b> | 32°F to 55°Fahrenheit                                              |
| <b>Storage Temperature:</b>   | -40°F to 167°Fahrenheit                                            |
| <b>Rel. Humidity:</b>         | 5% to 95%                                                          |
| <b>Power:</b>                 | 5V via PCI-Express Slot                                            |
| <b>Size:</b>                  | 112,30 x 120,00 mm                                                 |
| <b>Weight:</b>                | 200g                                                               |